

# HONDA 600 SEDAN

---

---

---

# OWNER'S MANUAL



## CONSUMER INFORMATION

### VEHICLE STOPPING DISTANCE

This figure indicates braking performance that can be met or exceeded by the vehicles to which it applies, without locking the wheels, under different conditions of loading and with partial failures of the braking system.

The information presented represents results obtainable by skilled drivers under controlled road and vehicle conditions, and the information may not be correct under other conditions.

Description of vehicles to which this table applies: HONDA 600 SEDAN

**A. Fully Operational Service Brake**

Load

Light

Maximum

**B. Emergency Service Brakes (with Partial Service Brake System Failure)**

**C. Brake Power Unit Failure**

Maximum Load

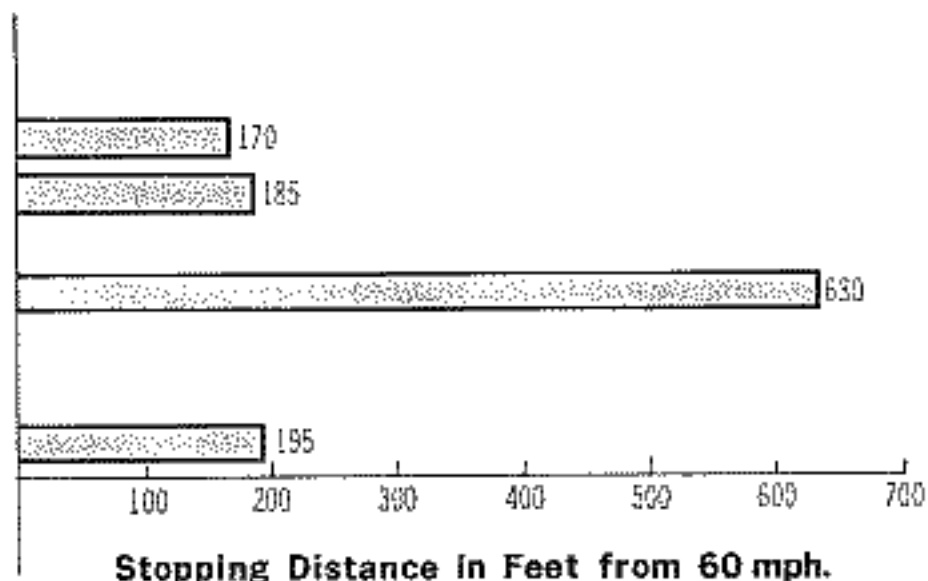

## ACCELERATION AND PASSING ABILITY

This figure indicates passing times and distances that can be met or exceeded by the vehicles to which it applies, in the situations diagrammed on the next page.

The low-speed pass assumes an initial speed of 20 MPH and a limiting speed of 35 MPH. The high-speed pass assumes an initial speed of 50 MPH and a limiting speed of 80 MPH.

NOTICE: The information presented represents results obtainable by skilled drivers under controlled road and vehicle conditions, and the information may not be correct under other conditions.

---

Description of vehicles to which this table applies : HONDA 600 SEDAN

---

### SUMMARY TABLE :

Low-speed pass .....	<u>395.3</u> Feet ; <u>8.9</u> Seconds
High-speed pass .....	<u>1917.0</u> Feet ; <u>22.7</u> Seconds

## LOW-SPEED

INITIAL SPEED : 20MPH

LIMITING SPEED : 35MPH

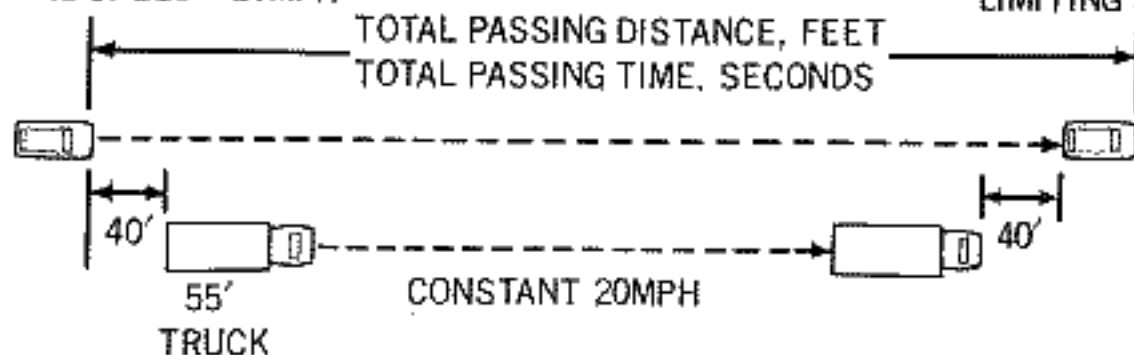

## HIGH-SPEED

INITIAL SPEED : 50MPH

LIMITING SPEED : 80MPH

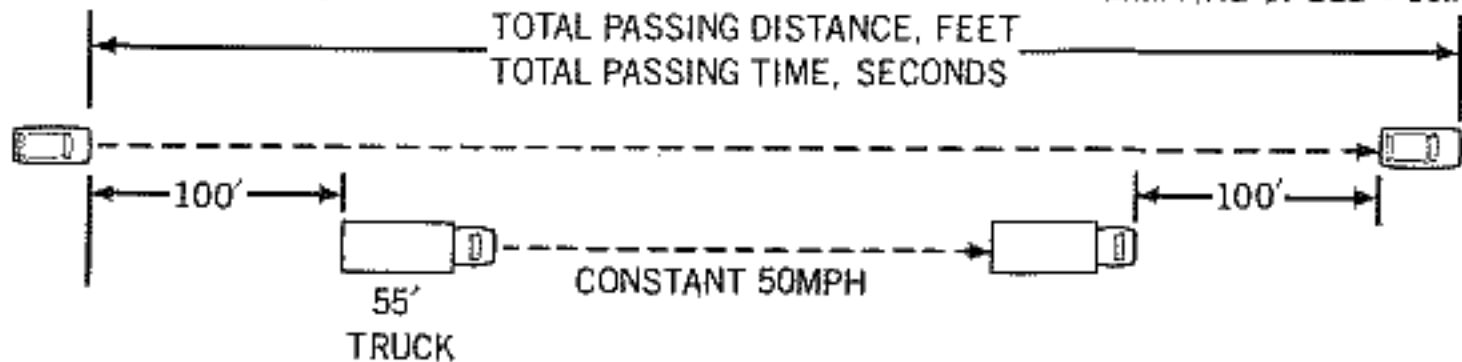

## TIRE RESERVE LOAD

This table lists the tire size designations recommended by the manufacturer for use on the vehicles to which it applies, with the recommended inflation pressure for maximum loading and the tire reserve load percentage for the tire listed. The tire reserve load percentage indicated is met or exceeded by each vehicle to which the table applies:

Description of vehicles to which this table applies: HONDA 600 SEDAN

Recommended tire size designations	5.20 - 10	
Recommended cold inflation pressure for maximum loaded vehicle weight	Front	30 psi
	Rear	24 psi
Tire reserve load percentage*	8.3	

\* The difference, expressed as a percentage of tire load rating, between (a) the load rating of a tire at the vehicle manufacturer's recommended inflation pressure at the maximum loaded vehicle weight and (b) the load imposed upon the tire by the vehicle at that condition.

**Warning.** Failure to maintain the recommended tire inflation pressure or to increase tire pressure as recommended when operating at maximum loaded vehicle weight, or loading the vehicle beyond the capacities specified on the tire placard affixed to the vehicle, may result in unsafe operating conditions due to premature tire failure, unfavorable handling characteristics, and excessive tire wear. The tire reserve load percentage is a measure of tire capacity, not of vehicle capacity. Loading beyond the specified vehicle capacity may result in failure of other vehicle components.



# INTRODUCTION

This manual contains important and helpful information on the proper operation and servicing of your HONDA 600 SEDAN.

As with all precision machinery, your HONDA 600 SEDAN will require periodic preventative maintenance to assure you of maximum economy, performance and reliability. Maintenance instructions are provided for your information, however, preventative maintenance services should be performed by a qualified HONDA technician.

HONDA MOTOR CO., LTD.

---

# HONDA

## 600

### CONTENTS

---

MAIN FEATURES .....	3
SAFETY ITEMS TO REMEMBER.....	4
IDENTIFICATION NUMBERS.....	5
IMPORTANCE OF YOUR KEYS.....	6
INSTRUMENTS AND CONTROLS .....	7
STARTING THE ENGINE AND DRIVING .....	28
PERIODIC MAINTENANCE.....	32
RECOMMENDED CAR CARE.....	33
GENERAL SPECIFICATIONS .....	62
INDEX .....	64



## MAIN FEATURES

The HONDA 600 SEDAN constitutes a new concept in automobile design which combines high performance with the economy and utility of a sedan. Features include a front mounted, air cooled, single overhead camshaft engine; front wheel drive; four-passenger seating and unitized (monocoque) body construction.

## ENGINE

- ◆ High power output with an exceptionally flat torque curve.
- ◆ Single overhead camshaft (SOHC) design which allows easy maintenance and valve clearance adjustment.
- ◆ Integral design of engine, transmission and differential requires only one oil supply.

## SAFETY FEATURES

- ◆ Complies with all applicable U. S. Federal Motor Vehicle Safety Standards.
- ◆ A clean instrument panel free from hazardous protrusions with safety padding on the upper edge.
- ◆ Recessed door handles to eliminate protrusions and to prevent accidental door opening.
- ◆ Adjustable head restraints on front seats.
- ◆ Power assisted front disc brakes.
- ◆ Dual hydraulic brake system with failure warning light.
- ◆ Hazard warning flasher system.
- ◆ Combination ignition and steering lock switch.

# **SAFETY ITEMS TO REMEMBER**

Your safety and that of your passengers depend upon your alertness as a driver and upon the condition in which you maintain your automobile.

**We recommend that you check the following items periodically.**

- 1. Service brake efficiency, pedal travel and hydraulic fluid level.*
- 2. Operation of all lights including headlights, tail lights, side marker lights, stop lights, turn signal lights, brake emergency warning light and hazard warning system.*
- 3. Tire pressures, examine tires for cuts and uneven or excessive wear.*
- 4. Steering for excessive play or vibration while driving.*
- 5. Exhaust system for leaks.*
- 6. Operation of windshield wipers and washers.*
- 7. Mirror adjustment and cleanliness of windows.*

**Before driving your car check the following : —**

1. Are you and your passengers wearing correctly adjusted seat belts?
2. Are the front seat head restraints properly adjusted?
3. Are the doors closed properly?

**While driving watch for changes in : —**

1. Weather as it affects road surface conditions and visibility.
2. Traffic density.

## IDENTIFICATION NUMBERS

1. The **vehicle identification number (V.I.N.)** is embossed on a plate affixed to the top surface of the instrument panel on the driver's side. Do not put things on the plate. This is for your protection to aid in the recovery of stolen vehicles and to serve as a deterrent to theft.
2. The **identification plate** is located on the right front fender under the hood.
3. The **chassis number** (identical to the V. I. N.) is stamped on the upper dashboard in the engine compartment in front of the air cleaner case.
4. The **engine number** is stamped on the crankcase.

ALWAYS ORDER REPLACEMENT PARTS BY  
V. I. N. AND ENGINE NUMBER





## **IMPORTANCE OF YOUR KEYS**

The larger key with the plastic head operates the ignition switch. The door locks and trunk lid lock are operated by the smaller key.

\* Before leaving your car, ask yourself these questions:

1. Is the ignition key removed from the switch?
2. Is the parking brake properly set?
3. Is the shift lever in low or reverse gear?
4. Are all windows closed?
5. Are both doors locked?

To deter car thieves, make a habit of removing the ignition key and locking the doors.

The code number of your door key is stamped on the small round plate attached to the key ring. The ignition key number is stamped on the key. Record these numbers so that you may have additional keys made in case the original sets are lost.

After recording the door key code number, the plate should be removed.

# **INSTRUMENTS AND CONTROLS**

INSTRUMENT PANEL .....	8
DOOR LOCKS .....	10
HOOD LATCH .....	11
TRUNK LID LOCK .....	12
EXTENDING THE LUGGAGE COMPARTMENT .....	12
VENTILATION.....	13
SEATS.....	14
COMBINATION LAP AND SHOULDER BELTS .....	15
LIGHTING SWITCH.....	20
HEADLIGHT DIMMER SWITCH .....	20
TURN SIGNAL SWITCH .....	21
INTERIOR LIGHT SWITCH .....	21
WINDSHIELD WIPER AND WASHER .....	22
HAZARD WARNING SYSTEM.....	23
BRAKE EMERGENCY WARNING LIGHT.....	23
HEATER AND WINDSHIELD DEFROSTER .....	24
FUEL FILLER LID .....	24
LIGHTER AND ASHTRAYS.....	25
INSTRUMENTS.....	26
IGNITION SWITCH .....	27

## INSTRUMENT PANEL

- ① Lighting switch
- ② High beam indicator
- ③ Parking brake warning light
- ④ Fuel gauge
- ⑤ Discharge warning light
- ⑥ Turn signal indicator
- ⑦ Fasten belt light
- ⑧ Speedometer
- ⑨ Odometer
- ⑩ Brake emergency warning light
- ⑪ Ashtray
- ⑫ Heater/Defroster control knob
- ⑬ Glove compartment latch button
- ⑭ Hazard warning flasher switch
- ⑮ Turn signal/Headlight beam switch
- ⑯ Windshield wiper/washer switch
- ⑰ Choke knob
- ⑱ Horn button
- ⑲ Clutch pedal
- ⑳ Brake pedal
- ㉑ Ignition switch
- ㉒ Accelerator pedal
- ㉓ Parking brake lever
- ㉔ Heater control lever
- ㉕ Lighter
- ㉖ Gear shift lever

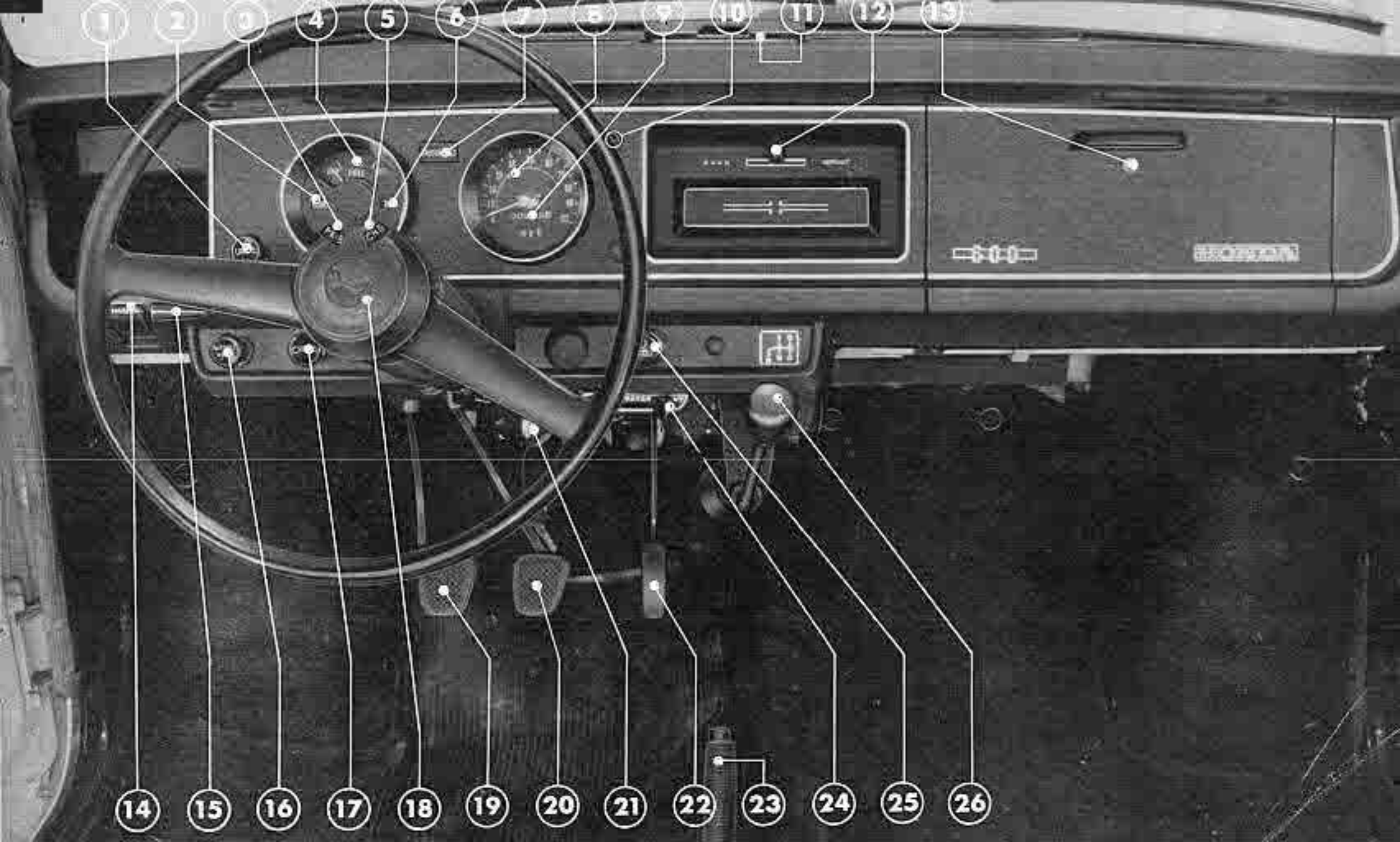

1

2

3

4

5

6

7

8

9

10

11

12

13

14

15

16

17

18

19

20

21

22

23

24

25

26

## DOOR LOCKS

1. To lock the doors from the outside, turn the key toward the front of the car. To unlock the doors from the outside, turn the key toward the rear of the car.
2. To lock the doors from the inside, close the door and push the door lever forward. The doors can not be locked by pushing the door lever forward before closing the door. This arrangement will prevent you from being accidentally locked out with the keys left inside the car.
3. To open the doors from the inside, pull the lever rearward.
4. For added safety, always lock both doors when driving.
5. The ignition key removal warning buzzer is provided to warn the driver against leaving the ignition key in an unattended car. The warning buzzer will sound whenever the key is left in the ignition switch and the driver's door is opened. The steering column will lock automatically whenever the ignition key is removed from the switch.

**NOTE:** If the door lock becomes frozen in very cold weather, it can usually be thawed out by heating the key and quickly inserting it into the lock cylinder. Repeat the procedure several times if necessary.

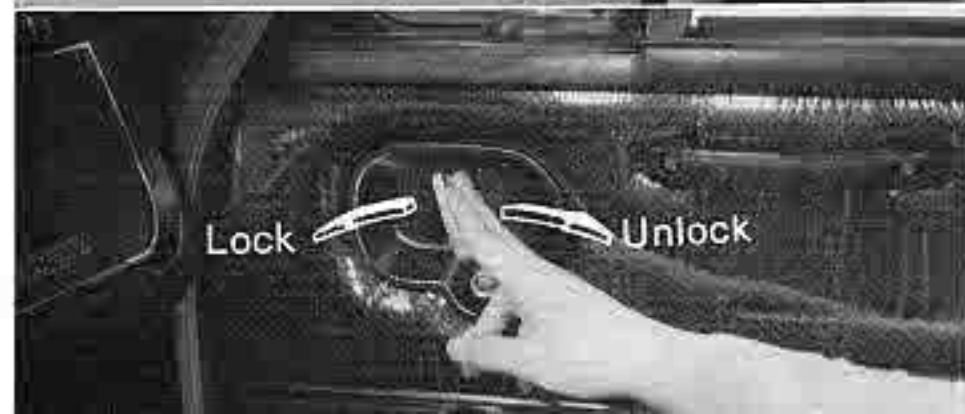
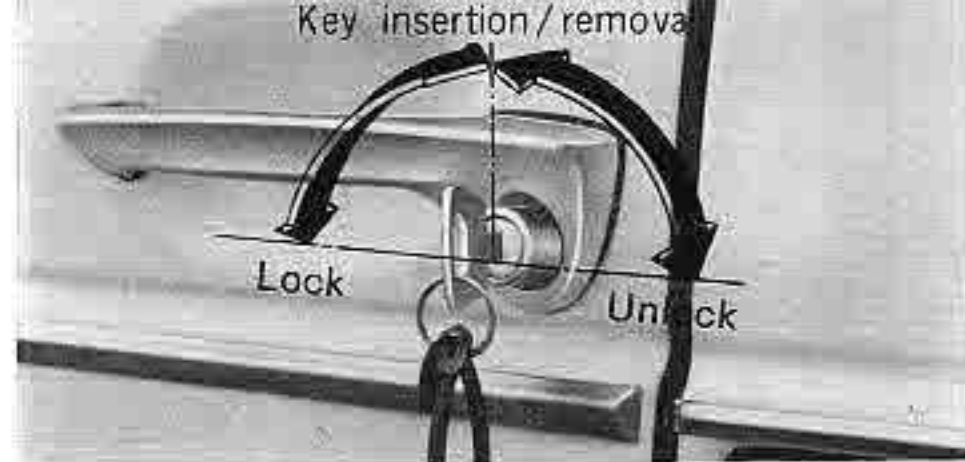



## HOOD LATCH

1. Push the release lever located at the center of the grill to the right.
2. Push the hood release safety latch in and raise the hood. Whenever the hood is raised, install the support as shown in the picture.
3. To close, remove the hood support and push the hood down firmly.
4. Check to insure the hood has locked into the closed position by trying to lift the front edge.

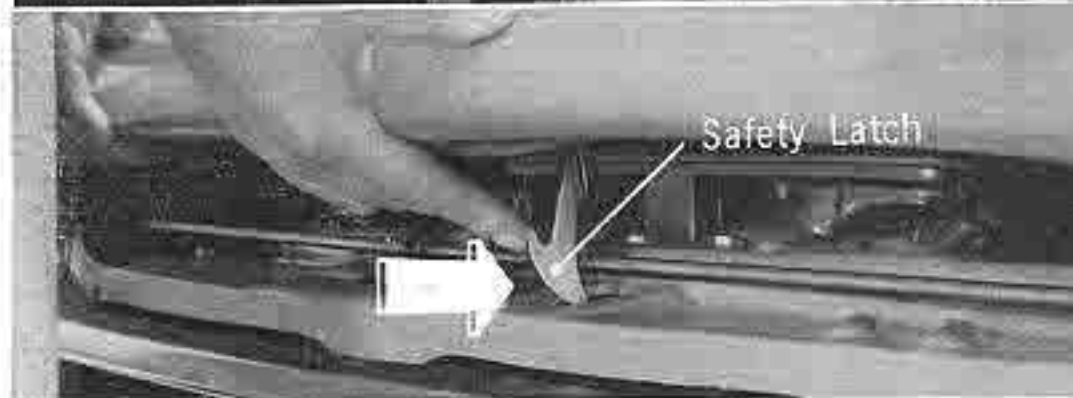
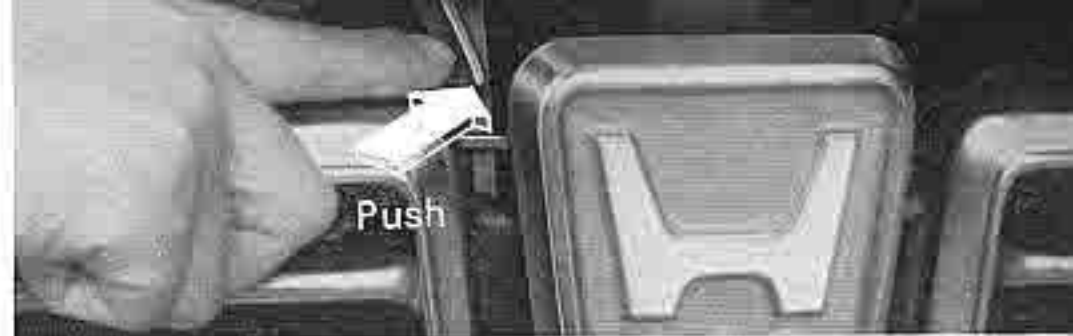

## TRUNK LID LOCK

1. The door key is used to unlock the trunk.
2. When unlocked, a release spring will open the lid slightly.
3. Raise the lid until it locks into position.
4. To close: push the lid down, the trunk lid will lock automatically.

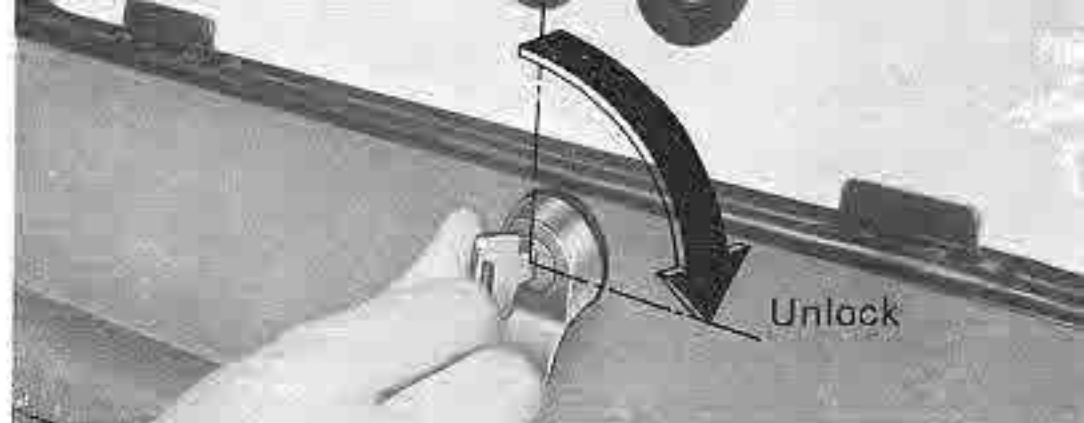

## EXTENDING THE LUGGAGE COMPARTMENT

After opening the trunk lid, remove the two wing nuts and one wing bolt. The seat back may now be laid on the seat cushion, stowed between the front seats and the rear seat cushion or removed from the car. If more space is required, remove the rear seat cushion by first removing cushion retaining bolt. Then lift the back edge and push the front edge back and up. The bracket may also be removed. Be careful not to lose the nuts, bolt and bracket.

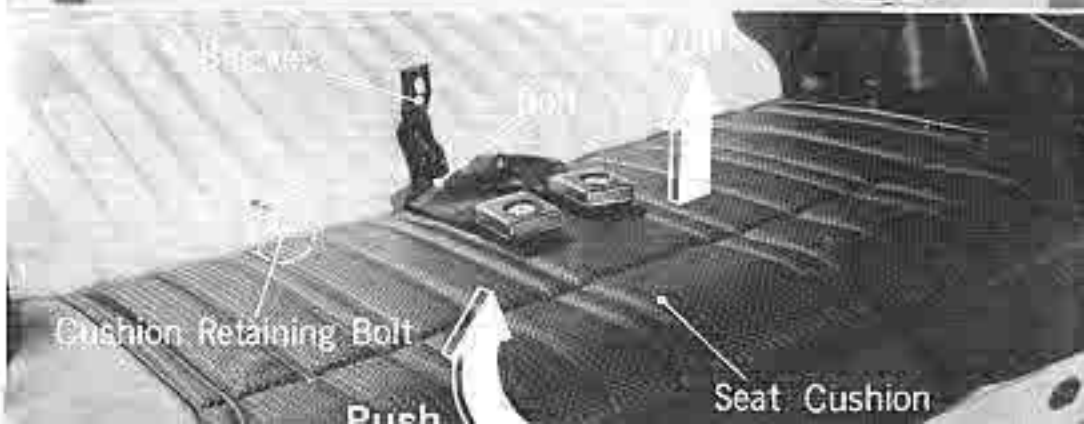
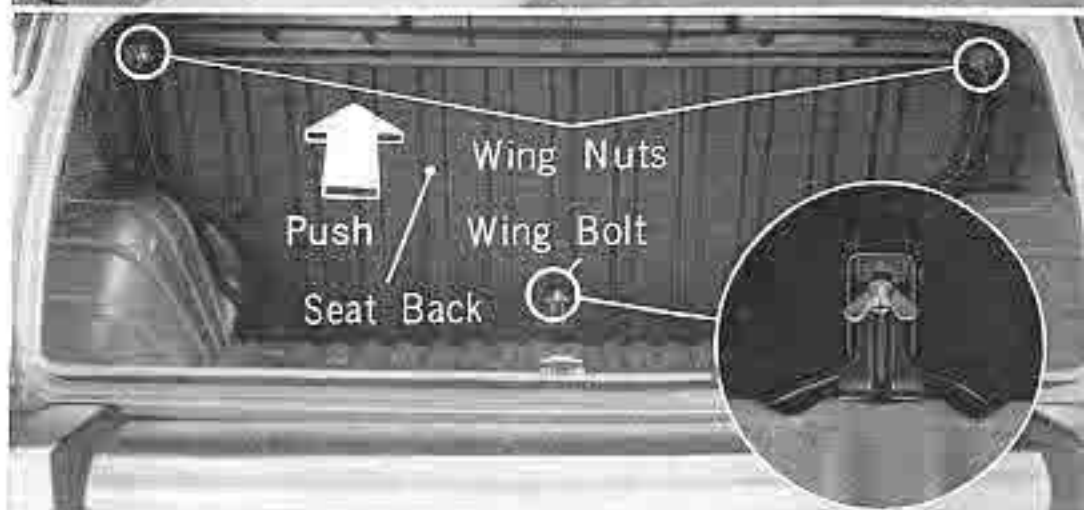

## VENTILATION

### AIR DUCTS

Fresh air ducts are mounted on the panels directly below the dash. To open the ventilators, lift the door up.

### DOOR VENTILATOR WINDOW

To open the door ventilator window, depress the lock button and rotate the lever forward.

### REAR SIDE WINDOWS

#### To Open:

Pull the lower end of the latch upward then push it outward to lock it in position.

#### To Close:

Pull the inner end of the latch upward then push it down to lock it in position.

### SUMMER TIME VENTILATION

For maximum ventilation, open the air ducts, door ventilator windows and rear side windows.

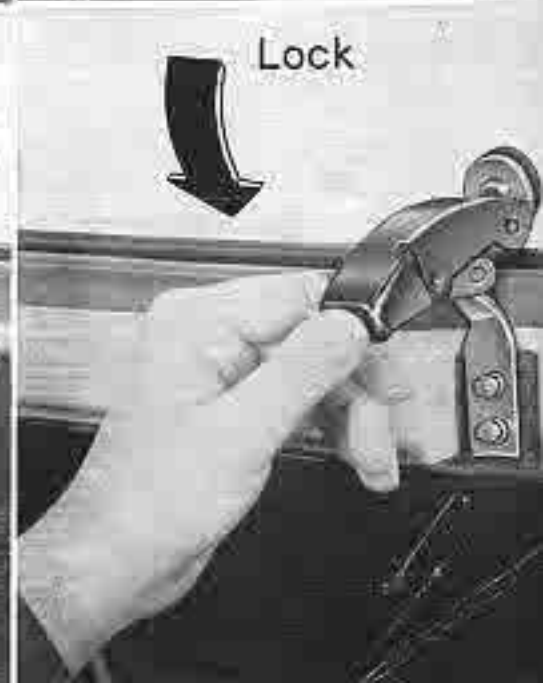
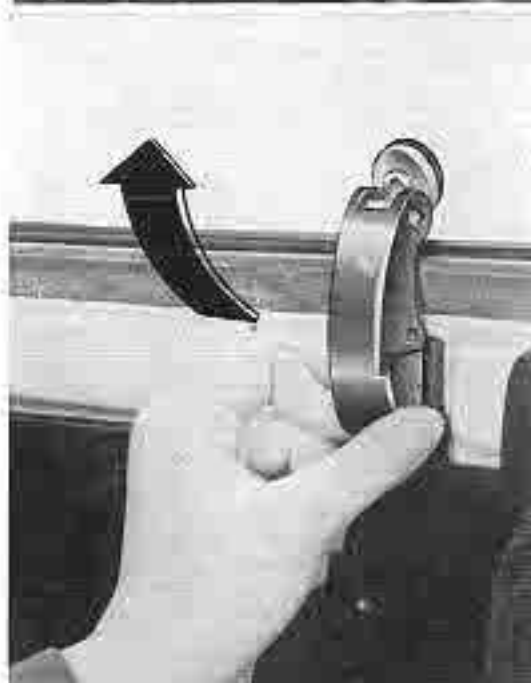
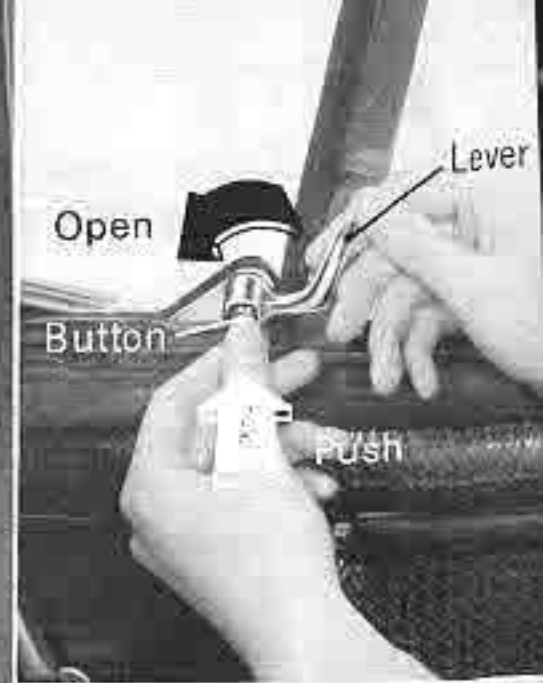

## SEATS

The seats may be adjusted in any one of eight different positions within a range of 6 1/4 inches (160 mm). To adjust, lift the adjuster lever located at the right front of each seat and move the seat in the desired direction. The seat will lock in position when the lever is released. After releasing the lever, try to move the seat both backward and forward to insure that it has locked in place. For access to the rear seat, tilt the seat back forward while pulling up the knob.

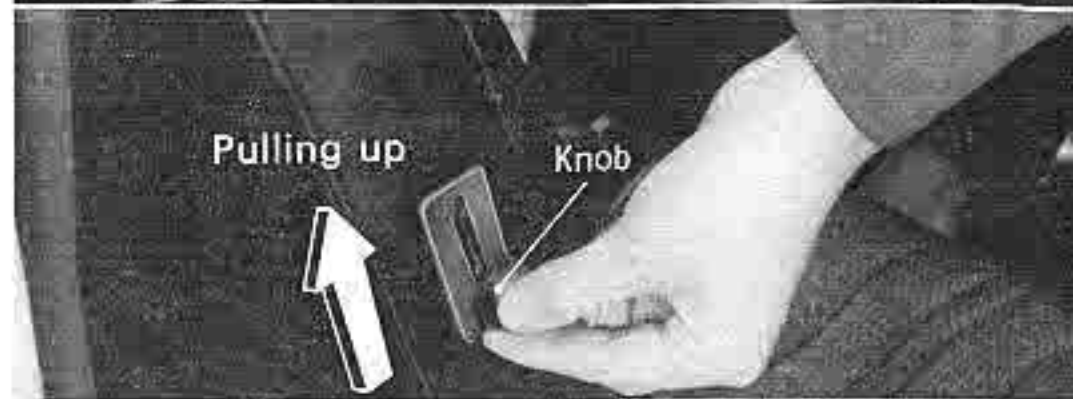

## HEAD RESTRAINTS

The head restraints are adjustable. Normally the adjustment is correct when the top of the restraint is above or at the same height as the center of your head.

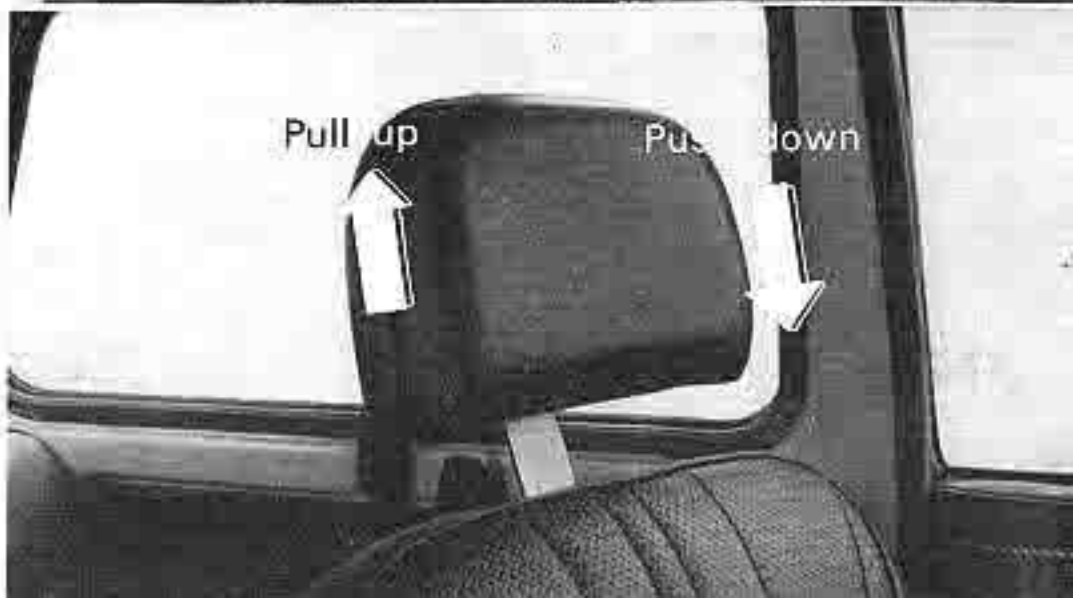

## COMBINATION LAP-SHOULDER BELTS

The seat belt is the most important single safety measure available to you and your passengers. Make sure that you and your passengers ALWAYS fasten the seat belts before the car is put in motion.

The FASTEN BELT lamp under the headlight switch will light and the buzzer will sound when the ignition switch is on, the parking brake is released and you or your front seat passenger do not have your seat belts fastened.

**NOTE:** Packages placed on the front passenger's seat may activate the seat belt warning system. Should this happen, the packages should be placed elsewhere.

The belts, anchorages and fasteners should be examined periodically for fraying, looseness, wear or other damage and replaced or tightened as necessary. The belts should be replaced after they have been subjected to collision loading. To clean the belts, hand wash them in warm water with mild soap and dry them thoroughly before reinstallation. DO NOT bleach or dye belts as this may cause a severe loss of strength.

The shoulder belt SHOULD NOT be worn by children weighing less than 50 pounds or under 55 inches in height as there is a risk of injury to such a person due to the position of the belt. In the above case, only the lap belt should be worn.

## Seat Belt Arrangement

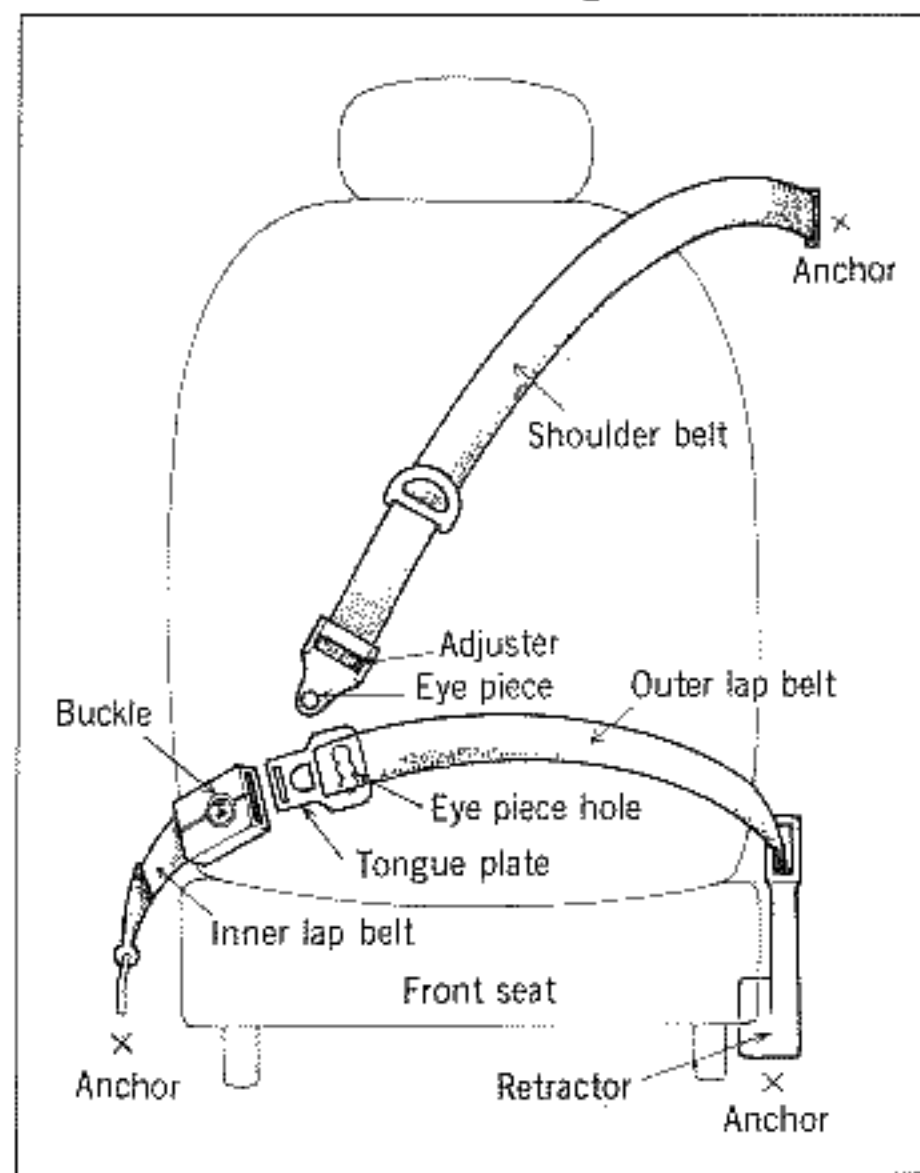

## FRONT LAP BELTS

First adjust the front seat to the proper position. Make sure that the belt is free from obstruction and not twisted. Pull the outer lap belt and insert the tongue plate into the slot in the buckle until a snap is heard. Make sure that the connection is secure.

If the outer lap belt locks before it is in position, return it to the holder and pull it out again.

A low, snug fit of the lap belt is essential in order that the pressure exerted by the belt in a collision may be spread over the strong pelvic area and not over the soft abdominal area.



To release the belt, depress the emblem plate on the buckle.

## REAR LAP BELTS

Make sure that the belt is free from obstruction and not twisted. Pull the outer lap belt and insert the tongue plate into the slot in the buckle until a snap is heard. Make sure that the connection is secure.

If the outer lap belt locks before it is in position, return it to the holder and pull it out again.

A low, snug fit of the lap belt is essential in order that the pressure exerted by the belt in a collision may be spread over the strong pelvic area and not over the soft abdominal area.

## SHOULDER BELT ADJUSTMENT

The lap belt must be worn correctly BEFORE the shoulder belt can be adjusted properly. With the lap belt in the proper position make a preliminary adjustment of the shoulder belt before disconnecting the lap belt to attach the shoulder belt.

Adjust the shoulder belt as necessary so that, when the belt is passed across the chest, the eye piece on the shoulder belt reaches the eye piece hole of the lap belt. For proper adjustment, hold the adjuster of the shoulder belt upright against the shoulder belt and pull the end of the belt to the desired length.



Disconnect the lap belt and connect the shoulder belt to the lap belt tongue. With the shoulder belt attached to the lap belt, reconnect the lap belt and perform final adjustment of the shoulder belt. The shoulder belt is adjusted correctly when the belt is comfortably snug with one fist placed between belt and chest.





Attach the lower end of the shoulder belt to the anchor as shown when the belt is not used.

Holes for attaching the optional rear shoulder belts are provided in the rear pillars.

The use and adjustment procedures for the optional rear shoulder belts are the same as those for the front shoulder belts.



## LIGHTING SWITCH

Pull the two-position lighting switch.

**FIRST-POSITION:** Parking lights, instrument lights, tail-lights, side marker lights and license plate lights.

**SECOND-POSITION:** Headlights and all night-driving lights.

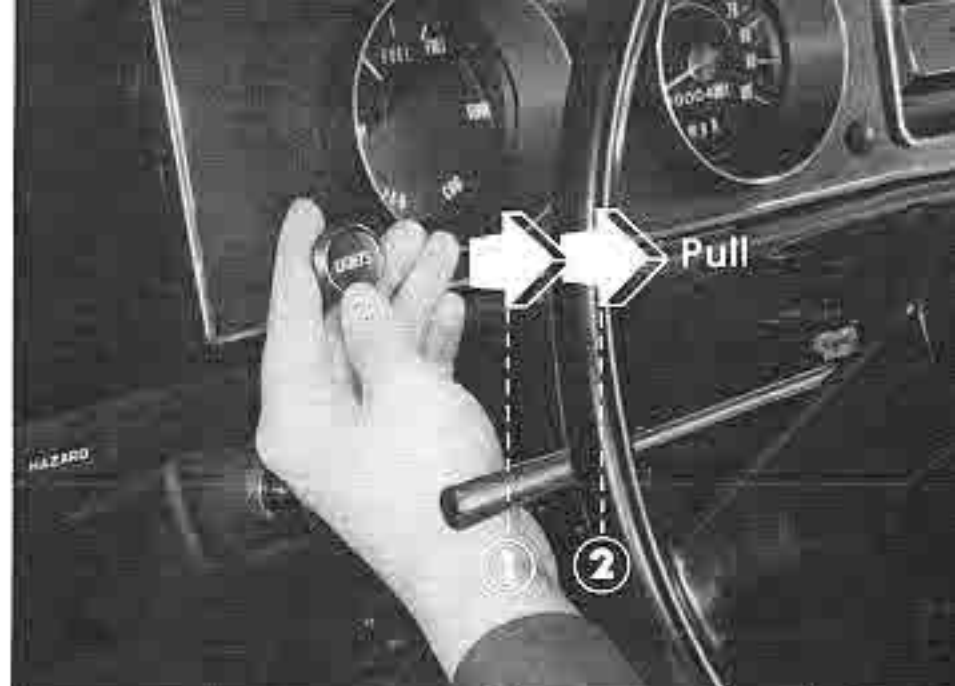

## HEADLIGHT DIMMER SWITCH

The headlights will be switched to the high beam and the high beam indicator light will glow when the beam switch lever (combined with turn signal switch lever) is pulled toward you. The lever will return to its original position automatically when released.

Pulling the lever again toward you will switch the headlights to the low beam and the indicator light will go off.



## TURN SIGNAL LIGHT SWITCH

Push the turn signal light switch lever down to operate the turn signals for a left turn, and up for a right turn. The indicator lamp and appropriate signal lamps will begin flashing.

The lever will return, automatically extinguishing the flashing lamps when the steering wheel is returned to a straight ahead position. After a wide sweeping turn, the turn signals may require manual cancellation.

If the indicator fails to flash, or if the flashing rate becomes very slow, the cause may be a burned out bulb. For safety, immediately replace any faulty bulbs.

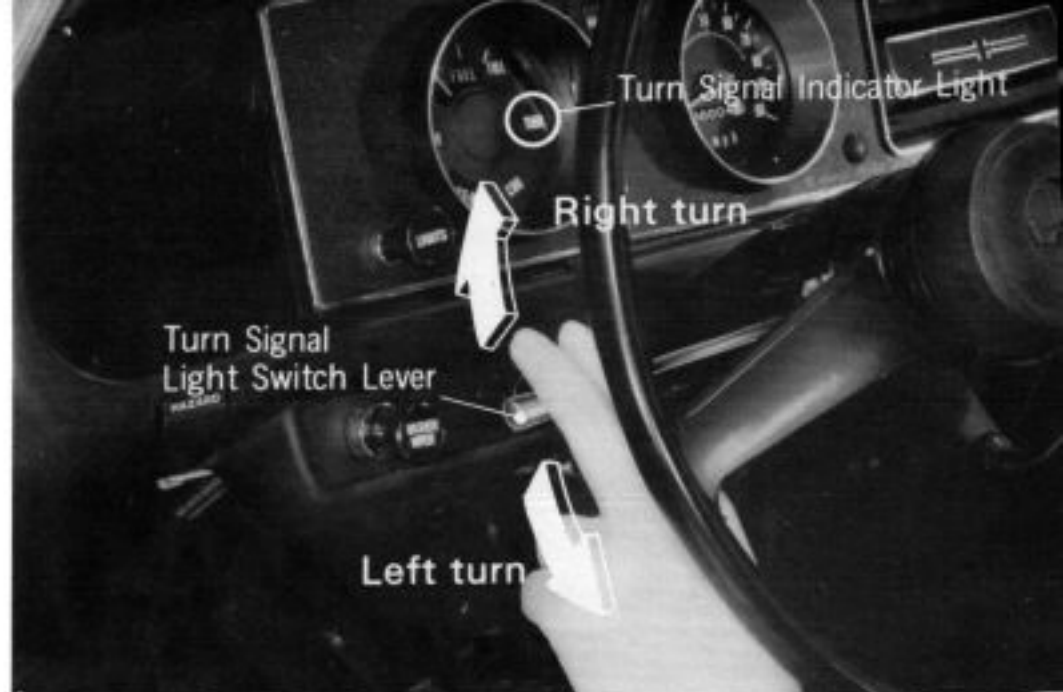

## INTERIOR LIGHT SWITCH

The interior lamp will light when the switch is turned to the ON position or when the driver's door is opened.

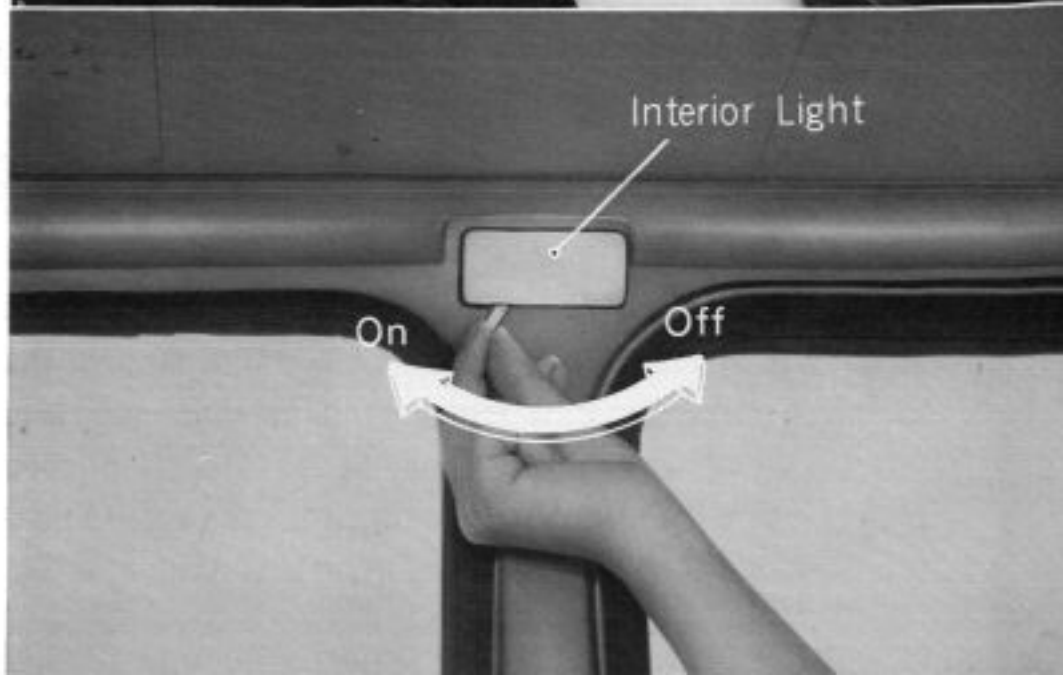

## WINDSHIELD WIPER AND WASHER

The windshield wiper/washer switch is located on the dash, to the left of the choke knob and steering column.

### WINDSHIELD WIPERS

The HONDA 600 SEDAN is equipped with two-speed windshield wipers. Turn the knob clockwise to the first stop for low speed operation or to the second stop for high speed operation.

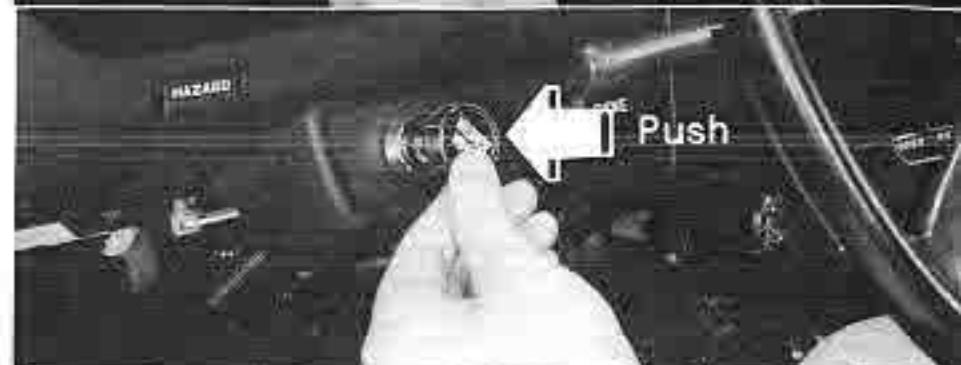

### WINDSHIELD WASHER

To operate the windshield washer, push the knob several times. The volume and pressure of the spray are directly related to the amount of force and frequency with which the knob is pushed. The washer fluid reservoir is mounted on the right front fender under the hood. The fluid level should be checked regularly. If no fluid appears and the reservoir is full, remove the cap and check to insure that the strainer at the end of the tube is unclogged. In cold weather, plain water may freeze; therefore, special windshield washer solution containing antifreeze should be used.



## HAZARD WARNING SYSTEM

This system should be used only when your car is stopped on the highway under emergency conditions. To operate the system, pull the red slide switch marked "HAZARD" which is mounted on the lower left corner of the dash. All four turn signal lamps and the indicator lamp will flash.

The hazard warning system operates independently of any other electrical system and is cancelled only when the switch is pushed in.



## BRAKE EMERGENCY WARNING LIGHT

The brake warning light is located on the instrument panel directly to the right of the speedometer.

The purpose of this light is to indicate a malfunction in the service brake system. In the event of a broken brake line or major brake fluid loss, the light will glow. Should this happen vehicle should not be driven until the cause has been determined and corrected.

**NOTE:** If the warning light electrical system is defective or the bulb is burned out, proper warning cannot be expected. Press the warning light lens before driving. If the light glows the system is working properly.



## HEATER AND WINDSHIELD DEFROSTER

To heat the interior, move the heater/defroster lever to the "ROOM" position and move the heater control lever to the first stop on the left. If more heat is desired, move the heater control lever completely to the left.

To defrost the windshield, move the heater/defroster lever to the "DEFROST" position and move the heater control lever to the first stop on the left. If more heat is desired, move the heater control lever completely to the left.

## FUEL FILLER LID

To open the fuel filler lid, open the left door and pull the lid release knob to release the latch.

Use **Low-lead** gasoline with **91** research octane number or higher is recommended. If such gasoline is not available, you may use a leaded regular grade gasoline.

### Fuel Warning-

Fuel is extremely hazardous under certain conditions. Always stop the engine and never allow sparks or open flames near the vehicle when refueling. If gasoline fumes are noticed while driving, the cause should be determined and corrected immediately.

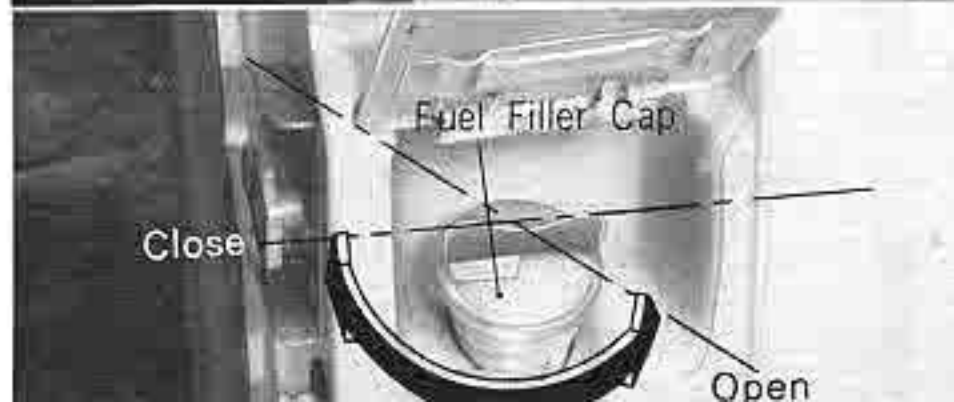

## LIGHTER

Push the lighter in to use. When ready for use, the lighter will spring back to its normal position with a snapping sound.

## ASHTRAYS

The front ashtray is mounted on top of the dash. To open it, lift the lid. To remove it, open the lid and lift up. The rear ashtray is mounted in the body pillar behind the passenger's seat. To open it, pull out on the upper lip. To remove the rear ashtray, open it, then push down on the spring as shown in the illustration.



## INSTRUMENTS

### SPEEDOMETER

Do not exceed the speed range indicated on the speedometer face for each gear. Do not downshift until the indicated speed is less than the maximum speed for the lower gear.

### ODOMETER

The odometer registers the total distance the vehicle has travelled. It is also your guide for determining when periodic maintenance is due.

### DISCHARGE WARNING LIGHT

Under normal driving conditions, the red discharge warning light (CHG) is off. If the light stays on, it indicates that the battery is not being charged. If this condition develops the charging system should be checked by a HONDA Automobile Dealer before the battery becomes completely discharged.

### PARKING BRAKE WARNING LIGHT

The parking brake warning (PK-B) lamp will glow when the parking brake is engaged and the key is in position II or III.

### FUEL GAUGE

Fuel tank capacity is 6.9 gallons. When the indicator needle points to "EMP", a usable reserve of about 1.3 gallons remain in the tank.

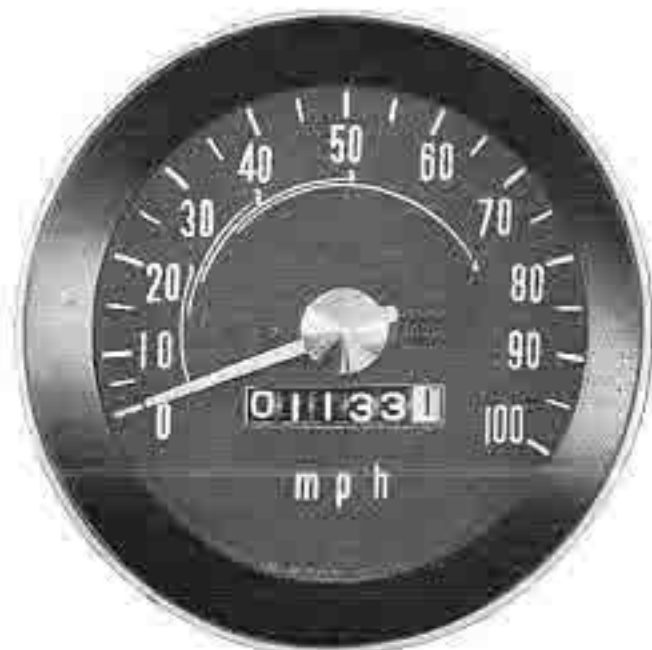



## IGNITION SWITCH

The ignition switch is integrated with the steering column lock and has four positions:

**0 POSITION** The key can be inserted or removed in this position **ONLY**. When the key is removed the steering column is locked. This feature provides additional protection against theft.

**I POSITION** This is the OFF position. The ignition and accessory circuits are off in this position. However the horn and lighting circuits for headlights, parking lights, hazard warning lights, tail lights and interior lights are energized.

**II POSITION** This is the normal "run" position.

**III POSITION** This is the starting position. The starter motor will engage when the key is turned to this position. If the engine fails to start the key must be turned back to the I POSITION before attempting to start the engine again. This arrangement protects against inadvertent starter operation while the engine is running.

**NOTE:** The warning buzzer will sound whenever the key is in the ignition switch and the driver's door is opened. If the key is hard to turn from 0 POSITION TO I POSITION, turn the steering wheel slightly to help release the steering column lock.

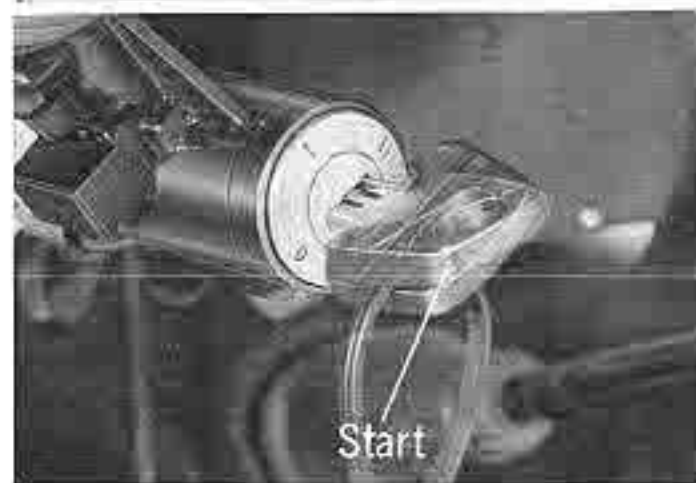
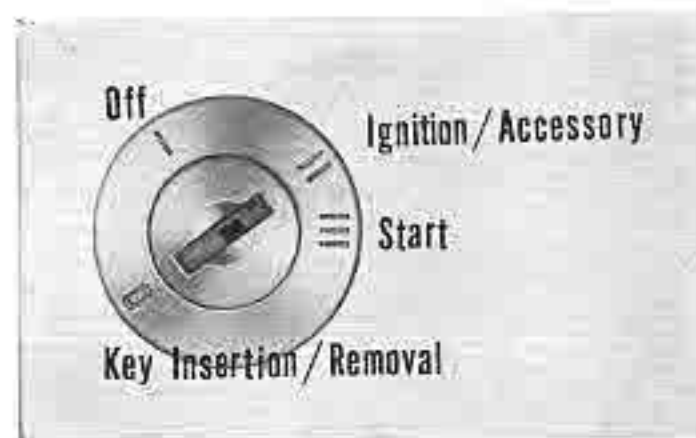

---

# STARTING THE ENGINE & DRIVING

---

<b>ENGINE STARTING PROCEDURE</b> .....	28
Exhaust Gas Warning.....	28
Engine Starting Procedure in Cold Weather.....	29
<b>DRIVING</b> .....	30
Gear Shifting .....	31
Recommended Speed Ranges .....	31
Engine Compression Brake.....	31

---

## ENGINE STARTING PROCEDURE

1. Depress the clutch pedal fully.  
Make sure that the gear shift lever is in the neutral position and the parking brake is engaged.
2. Turn the ignition key to the "II" position to start the engine. Choking is not necessary in warm weather.
3. After the engine starts, depress the accelerator pedal lightly. The vehicle is ready to drive when the engine is operating smoothly.

### Exhaust Gas Warning

Exhaust contains poisonous carbon monoxide gas. Never start or run the engine in a closed garage, or sit in a parked car for an extended period with the engine running.

The exhaust system should be inspected for proper mounting, exhaust leaks and missing or damaged parts each time the vehicle is raised for an oil change.

## Engine Starting And Warm-Up Procedure in Cold Weather

1. Pull choke knob out fully: Full stroke is 1 3/8 in. (3.5 cm).
2. Depress and release the accelerator pedal several times.
3. Turn the ignition key to start the engine. Do not depress the accelerator pedal.
4. Before driving, run the engine for several minutes. Adjust the choke knob so that the engine runs smoothly.
5. Warming up the engine is best accomplished by driving. Prolonged idling is a slow and inefficient way to warm up the engine and is not recommended. The choke knob should be pushed in gradually as the engine warms up.

**NOTE:** Make sure to depress the choke knob completely after the engine warms up. Otherwise poor fuel economy, fouling of spark plugs, and poor overall performance may occur.

If the engine does not start, do not continue cranking for longer than 15 seconds at any one attempt. Allow at least 30 seconds of rest between starting attempts. This will permit the battery to recover.

Depressing the accelerator pedal too often may foul the spark plugs, which will cause hard starting. If this occurs, depress the choke knob and operate the starter while depressing the accelerator pedal fully until the engine starts.

## Intake Air Temperature Control System

In cold weather (below 60°F), place the lever in the "WINTER" position to supply hot air to the carburetor. In the summer (above 60°F), move the lever to the "SUMMER" position.



Choke Knob



Fully choked



Choke half released



Intake Air Temp Control Lever

## DRIVING

1. Wear the seat belt properly.
2. Start the engine.
3. Depress the clutch pedal.
4. Move the gear shift lever into the first gear position.
5. Release the parking brake. The parking brake warning light on the instrument panel should go off.

The FASTEN BELT lamp will light up and the warning buzzer will sound if you and your passenger do not wear your seat belts. Fasten your seat belts correctly before putting the car in motion.

**NOTE:** Packages placed on the front passenger's seat may activate the seat belt warning system. In this event, the packages should be placed elsewhere.

6. Depress the accelerator pedal slightly and gradually release the clutch pedal. As the clutch engages the car will start moving slowly. Allow the clutch pedal to come all of the way out.
7. Gradually increase speed by depressing the accele-

rator. Do not exceed the maximum speed recommended for each gear.

8. In proper sequence, shift to higher gears by depressing the clutch, moving the shift lever to the gear desired, and releasing the clutch smoothly.

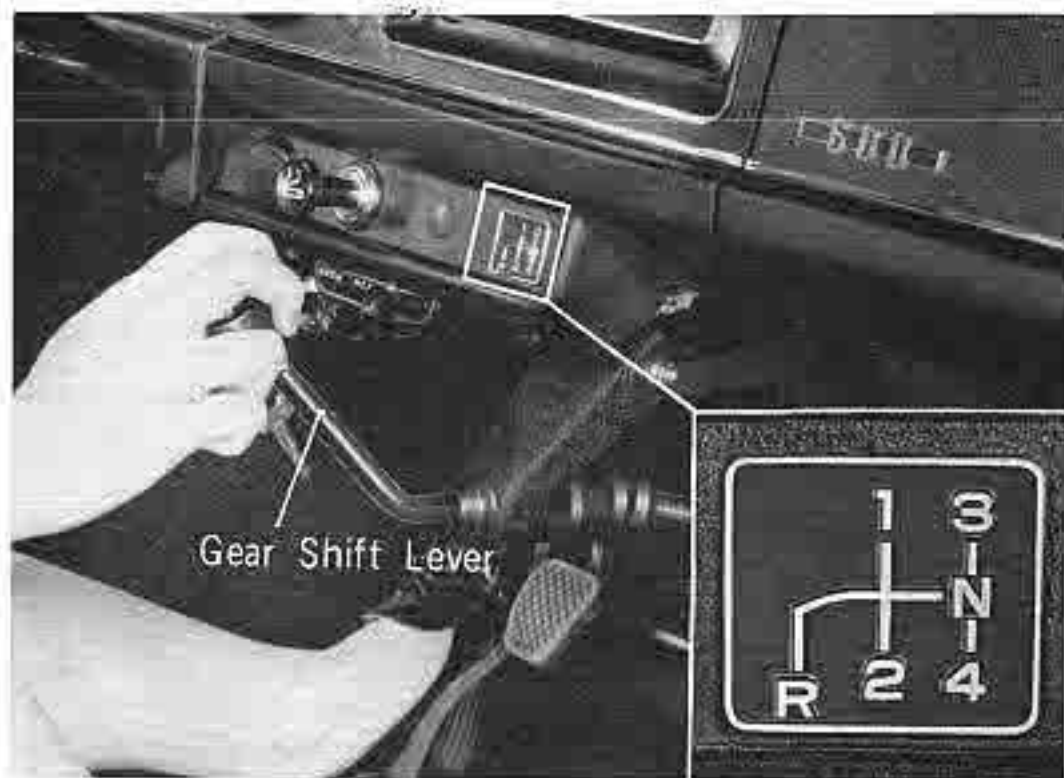

## Gear Shifting

The gear shift pattern is shown in the illustration on page 30.

### Recommended Speed Ranges

Change gears in accordance with the speed ranges indicated on the speedometer. Overrevving the engine or driving at speeds below the designated speed ranges will result in poor fuel economy and shortened engine life.

### WARNING

Do not use second, third or fourth gear to accelerate from a stop. Do not coast in Neutral (This practice is illegal in many states) Do not "speed shift", as this may damage the transmission. Never leave the vehicle unattended with the engine running.

Gear Positions	Recommended Speed Ranges
1 st gear	0~20 mph
2 nd gear	15~35 mph
3 rd gear	20~50 mph
4 th gear	30~75 mph

## Engine Compression Brake

When descending long, steep grades, continuous use of the service brake may result in excessive wear and overheating of the brake shoes and pads. Shifting down to a lower gear will result in a braking effect due to engine compression and thus minimize use of the service brake to maintain a safe speed. Do not select a lower gear until vehicle speed has been reduced to within the speed range of the gear to be selected.

## **PERIODIC MAINTENANCE—YOUR ASSURANCE OF HAPPY MOTORING**

### **PERIODIC MAINTENANCE IS IMPORTANT**

To maintain your HONDA 600 SEDAN in peak operating condition, periodic maintenance must be performed at proper intervals.

Periodic preventative maintenance is your assurance of trouble-free operation. **ANY PROBLEM WHICH OCCURS DUE TO LACK OF PERIODIC MAINTENANCE WILL DISQUALIFY THE VEHICLE FROM WARRANTY COVERAGE.** Always have the maintenance performed according to the schedule at a HONDA Automobile Dealership. The maintenance schedule is specified in the Owner's Warranty and Service Policy Manual. Be sure to present your manual to the servicing dealer so that the proper entries can be made to verify that the service was performed. If you have any questions concerning your HONDA 600 SEDAN your HONDA Automobile Dealer will always be happy to assist you.

# RECOMMENDED CAR CARE

CAR CLEANING .....	34
TOOL KIT .....	36
PROPER USE OF THE JACK .....	37
PERIODIC ROTATION OF TIRES.....	38
WHEELS - SNOW TIRES - TREAD WEAR INDICATOR .....	39
TOWING .....	40
BATTERY .....	41
FUSES.....	42
LIGHTING SYSTEM .....	43
BRAKE SYSTEM .....	47
LUBRICATION .....	50
OIL CHANGE .....	52
OIL FILTER CHANGE .....	53
AIR CLEANER ELEMENT.....	54
FAN BELT.....	55
SPARK PLUGS .....	56
VALVE CLEARANCE ADJUSTMENT .....	57
BREAKER POINT GAP .....	58
IGNITION TIMING .....	59
CARBURETOR ADJUSTMENT .....	60

## CAR WASHING AND POLISHING

### 1. WASHING AND WAXING

A build-up of dust, dirt, and road tar will affect the durability of any car's painted surface, therefore a program of washing and waxing is recommended at frequent intervals and particularly under the conditions noted below.

- A. After driving on wet roads especially through slush.
- B. After driving on a road which has been treated with salt to prevent freezing.
- C. When snow has piled up on the car or when it is coated with ice, the car should be washed down with warm water as soon as possible.
- D. Foreign substances adhering to the painted surface should be removed as soon as possible.

**NOTE:** Washing the car with detergent while the surface is still hot from being exposed to the sun is not recommended as this may cause spotting and discoloration. Washing should be performed when the paint surface is cool. Waxing should also be performed under the same conditions.

### 2. WASHING AND WAXING PROCEDURE

- A. Water down thoroughly with a hose and remove the dirt and sand with a sponge or soft rag.

**NOTE:** Work the sponge or rag lightly over the surface so as not to scratch the paint.

- B. Remove the water droplets with a chamois or doe skin, wringing it out often. Water droplets which are allowed to dry on the surface will leave stains.

**NOTE:** Chamois or doe skin will absorb dirt and sand. It should be washed out thoroughly after using and dried in the shade. Drying in the sun will cause it to become stiff. Sand remaining in the chamois will scratch the paint when next used.

### 3. EXCESSIVELY DIRTY SURFACE

- A. When the surface is coated with a thick layer of old wax, water will not run off. The old wax should be removed with a synthetic detergent and warm water. If the painted surface is hot, it will be stained. Tenacious or stubborn substances can be removed with polish or a cloth soaked with road tar remover followed immediately by washing.



- B. Grease or oil on the surface should be removed with a cloth soaked in road tar remover followed immediately by washing.
- C. Removing tar and asphalt.  
Use a standard automobile cleaner with a soft cloth and rub the surface lightly. If repeated rubbing of the surface is necessary, use a clean section of the cloth to prevent scratching. Wash immediately after the surface has been cleaned.
- D. When the surface is covered by salt after driving over a road treated with deicing salt compound, the automobile should be washed down with water especially around the seams and joints of the body panels.

- NOTE :**
- 1. The use of gasoline should be avoided since it has a tendency to soften the paint. When used follow immediately by washing.
  - 2. When using a steam cleaner, do not get the nozzle too close to the painted surface. Kerosene should not be mixed with the cleaning compound since it will damage the rubber sealing strips.

#### 4. APPLYING WAX

- A. Use a clean soft cloth and apply a good grade of automobile wax sparingly on the surface to give it a slight dull coating.

#### 5. POLISHING

- A. After the wax has dried to a chalky surface, polish with a soft cloth. This followed by treatment with a good grade liquid polish will produce a high gloss.

#### 6. CHROME PLATED SURFACES

- A. Chrome surfaces should be cleaned with warm water and synthetic detergent followed by rinsing with water

## TOOLS

### TOOL LIST

- |                         |                         |
|-------------------------|-------------------------|
| ① Jack                  | ⑦ 10×12 Open End Wrench |
| ② Jack Handle           | ⑧ 14×17 Open End Wrench |
| ③ Spark Plug Wrench     | ⑨ Screwdriver           |
| ④ Spark Plug Wrench Bar | ⑩ Screwdriver Handle    |
| ⑤ Wheel Wrench          | ⑪ Tool Bag              |
| ⑥ Pliers                |                         |

### TOOL KIT

The tool kit is located under the seat on the left side. The jack is stowed in the engine compartment in a slightly raised position to prevent it from coming loose. The jack must be lowered slightly before it can be removed.

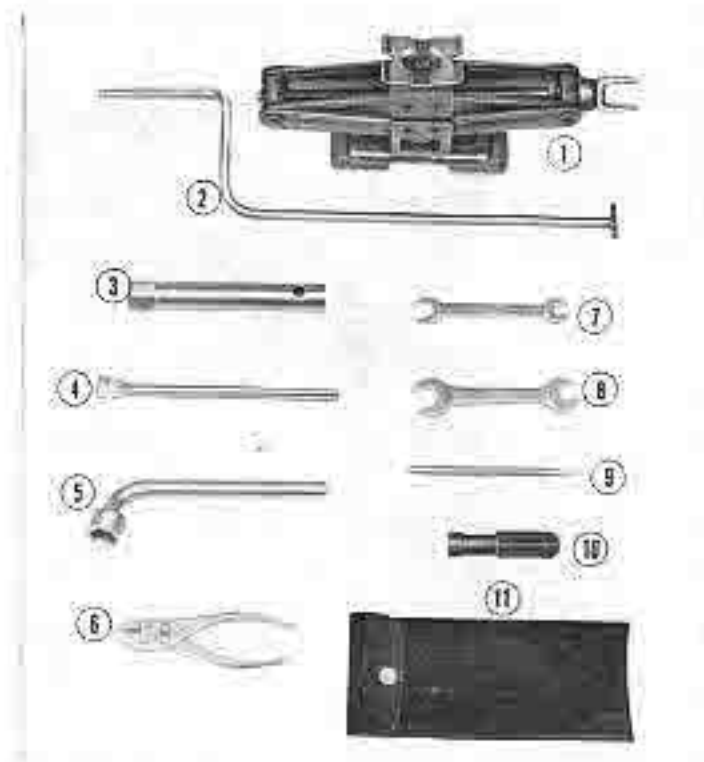

## PROPER USE OF THE JACK

Park the car on level ground.

When raising a **front wheel**, pull the parking brake lever until the rear wheels are locked to prevent the vehicle from rolling. Set the jack under the front end of the subframe.

When raising a **rear wheel**, put the transmission in first gear and block the front wheels to prevent rolling. Set the jack under the rear axle beam.

Do not extend the jack any higher than necessary.

**CAUTION:** Never get beneath the car when it is supported only by the jack. Always use safety stands to securely support the car.

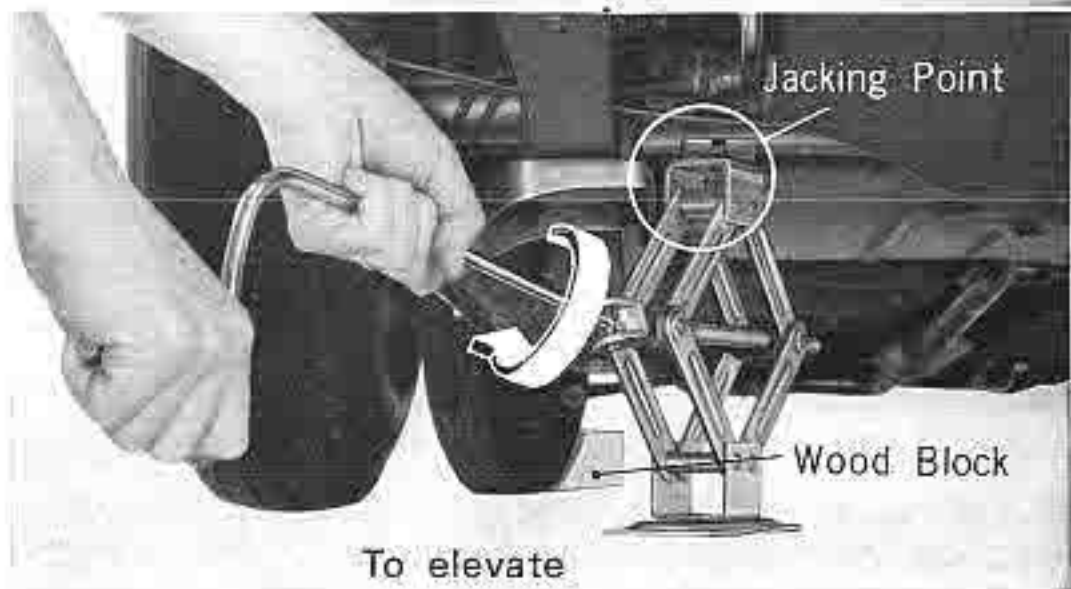
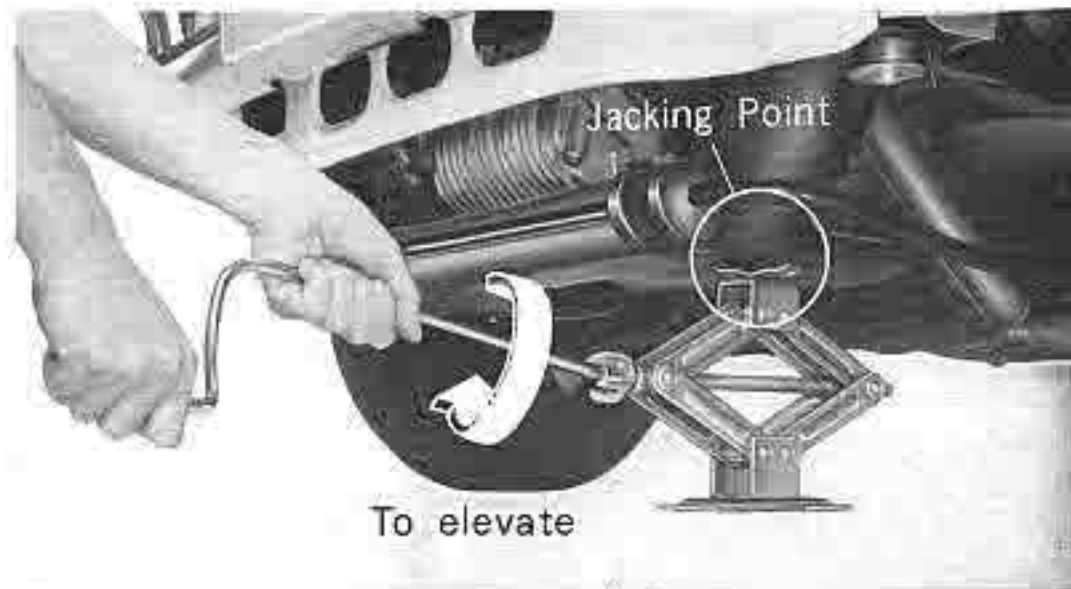

## WHEELS

- Loose wheel nuts are extremely hazardous. Tighten the nuts in the sequence shown in the figure. Fit the wheel wrench completely on the nut when tightening or loosening.
- Be sure the tires are always properly inflated. Low air pressure will cause excessive tire wear and hard steering; high air pressure will give an uncomfortable ride and poor braking.

### PROPER TIRE PRESSURES (COLD)

Bias Ply (5.20×10 Standard)

Front: 30 psi (2.1 kg/cm<sup>2</sup>) Rear: 24 psi (1.7 kg/cm<sup>2</sup>)

Radial Ply (145SR10 Optional)

Front: 26 psi (1.8 kg/cm<sup>2</sup>) Rear: 22 psi (1.6 kg/cm<sup>2</sup>)

## SNOW TIRE SNOW CHAIN

For driving on snow, mount snow tires (5.20-10) on the front and rear wheels. For driving on ice, snow tires with studs are preferable. For very heavy snow, chains may be installed on the front wheels. Snow tire chains, should be installed as follows:

1. Raise the front wheels off the ground.
2. Spread the chain nets under each wheel.
3. Fit the chain net around the tire, connect the ends and install the tensioner.

## TREAD WEAR INDICATOR

The tread wear indicators are molded into the bottom of the tread grooves of the tire. When these indicators appear as a half inch wide solid line, the tires should be replaced.

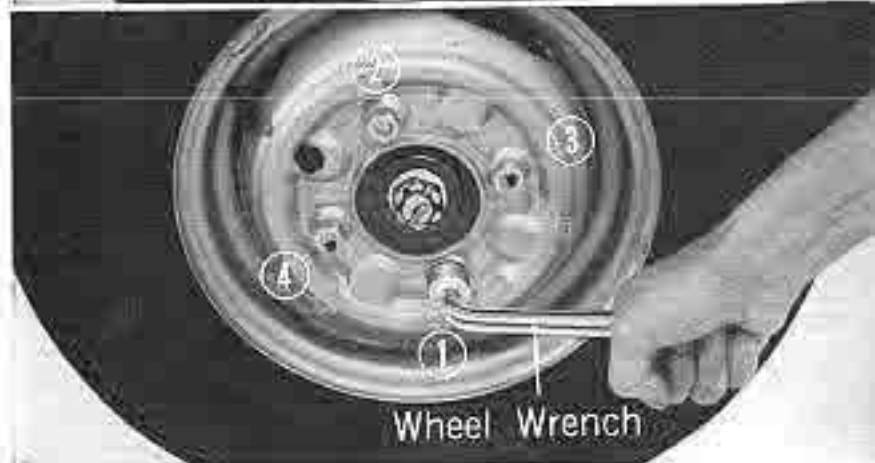

## PERIODIC ROTATION OF TIRES

Tires will wear unevenly when used for a long period of time at the same position. Therefore, the tires should be rotated periodically as shown in the illustration.

**Rotate the tires every 3,000 miles and also check the wheel balance. After the tire rotation is completed, reset tire pressure.**

When removing or installing the wheels, loosen and tighten the nuts in the sequence shown in the figure on the previous page.

### Removing the spare tire from the carrier pan

Fit the big end of the spark plug wrench over the hexagonal nut in the floor of the trunk. Loosen the nut (approximately 15 turns) and raise the carrier pan to release the pan retaining bolt. The pan may now be lower to the ground and the spare tire removed. If the pan retaining bolt interferes with the spare tire, lift the bolt up.

Reverse the above sequence to remount the spare tire and carrier. Make sure to tighten the pan retaining bolt securely.

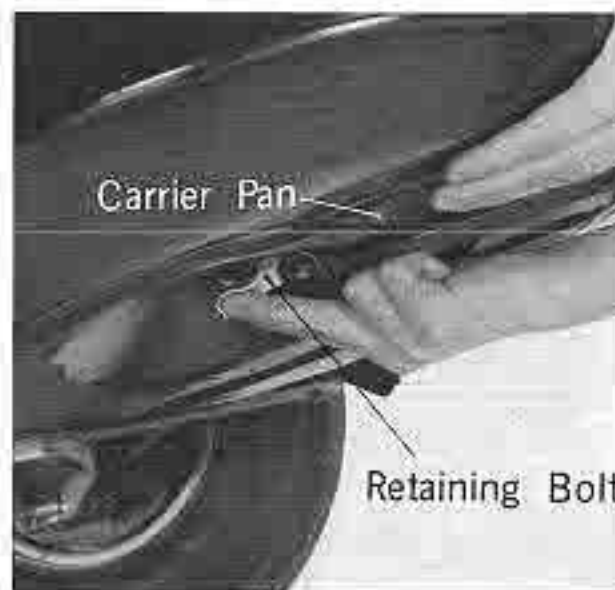
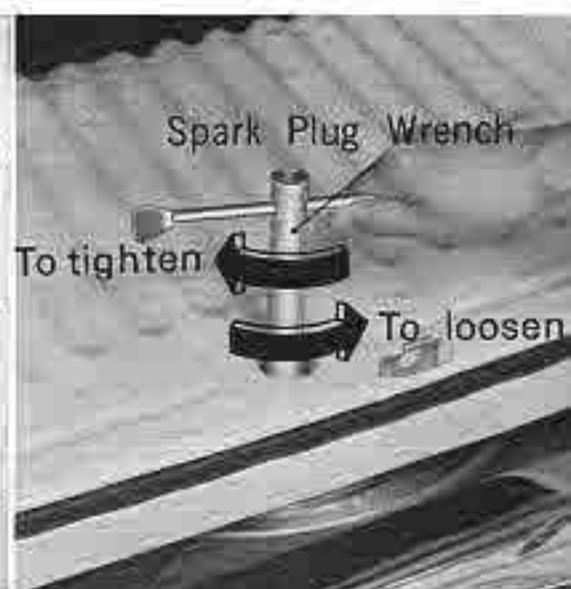
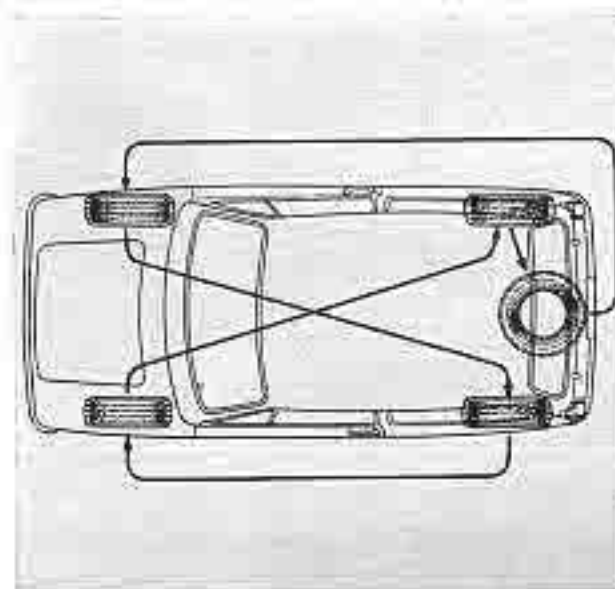

## TOWING

Be sure to check local regulations which may require the use of a tow bar and safety chains. If permitted, a rope may be attached at the point shown in the photograph.

A tow bar and safety chains must be used for high speed or long distance towing. Your HONDA 600 may be towed if the following precautions are observed:

1. Check the engine oil level and add oil to the full mark as necessary.
2. Turn the ignition key to the number 1 position and check to insure that the steering wheel turns freely.
3. Put the gear shift lever in the NEUTRAL position.

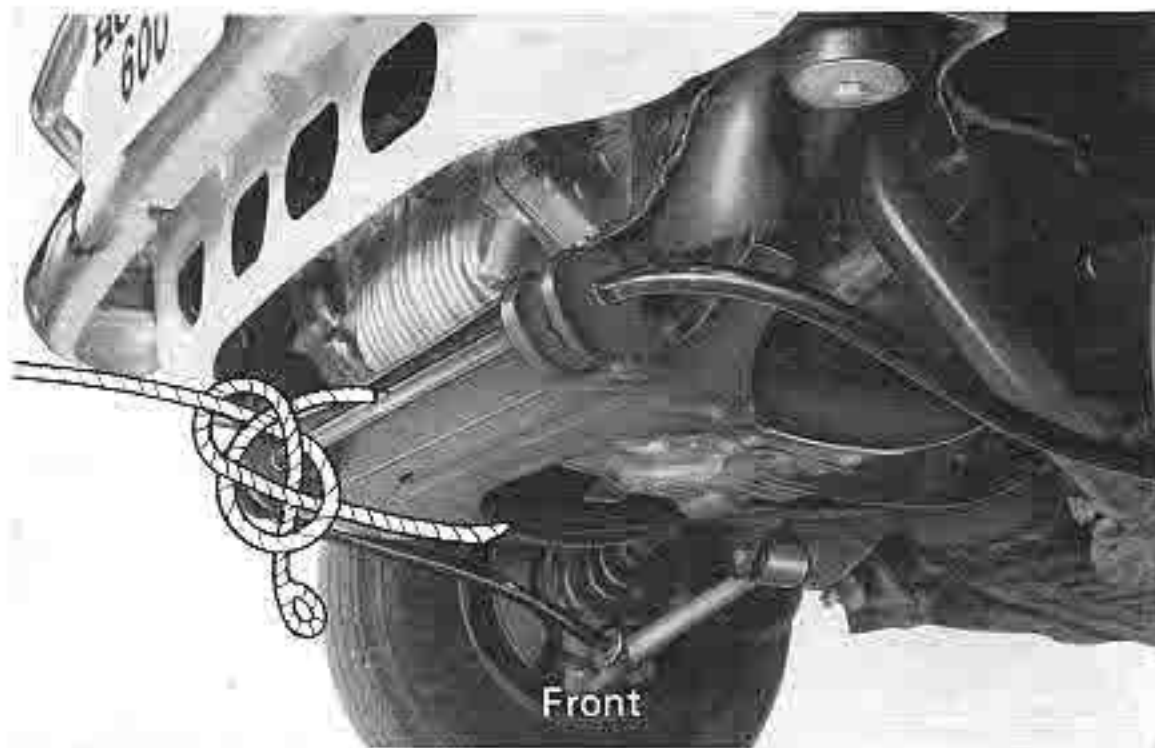

## BATTERY

Fill the battery with distilled water to the upper level shown in the figure. Never over-fill the battery. There is a tendency for corrosion to form around both the positive and negative terminals of the battery. Any corrosion should be washed off with a solution of baking soda and warm water and the terminals coated with grease or vaseline.

### Battery Warning

1. To prevent damage to the electrical system, never connect booster batteries in excess of 12 volts. Always connect positive to positive and negative to negative.
2. Keep open flames and sparks away from the battery. Normal battery chemical action generates highly explosive hydrogen gas. Also avoid contact of battery solution with skin, clothing, or painted surfaces. For safety, always wear eye protection when working on the battery.



## FUSES

WHENEVER A FUSE IS BLOWN, THE CAUSE OF THE PROBLEM SHOULD BE DETERMINED AND CORRECTED BY A QUALIFIED HONDA TECHNICIAN.

A blown fuse should never be replaced by anything other than a fuse of the specified rating. Use of a larger capacity fuse or a strip of wire may cause damage to the electrical equipment and may also cause a fire.

- ①.....Heater blower
- ②.....Spare (15A)
- ③.....Turn signal lights, windshield wipers, back-up lights, fuel gauge, parking brake indicator light, discharge warning light and heater blower overrun relay
- ④.....Spare (20A)
- ⑤.....Headlights, taillights, stop lights, license plate lights, parking lights, sid marker lights, brake emergency warning light, meter lights and fog lights (optional).
- ⑥.....Horn, ignition key warning buzzer, hazard warning flasher system, interior light, cigarette lighter, radio (optional) and clock (optional).

**NOTE:** The main fuse is installed on the right front fender beside the battery. In the event of an electrical overload, the 45A fuse will blow before damage occurs to the entire wiring harness. Always have your HONDA Automobile Dealer check the charging circuit if you experience any problem with this fuse.

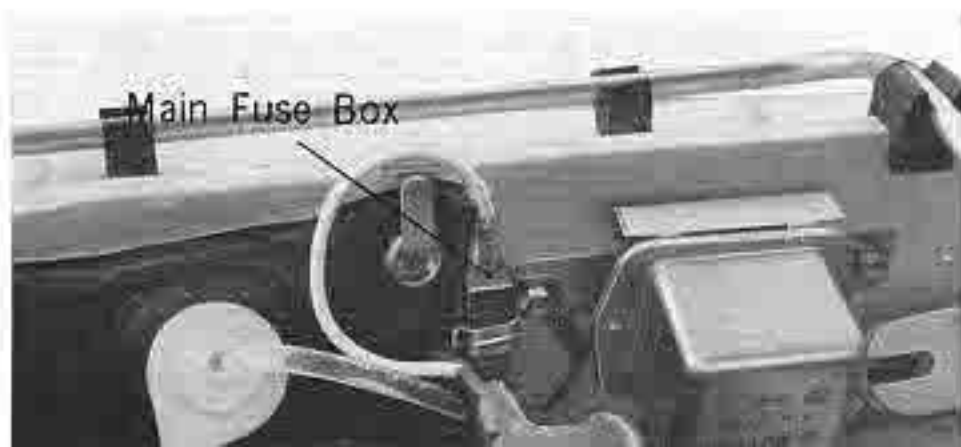
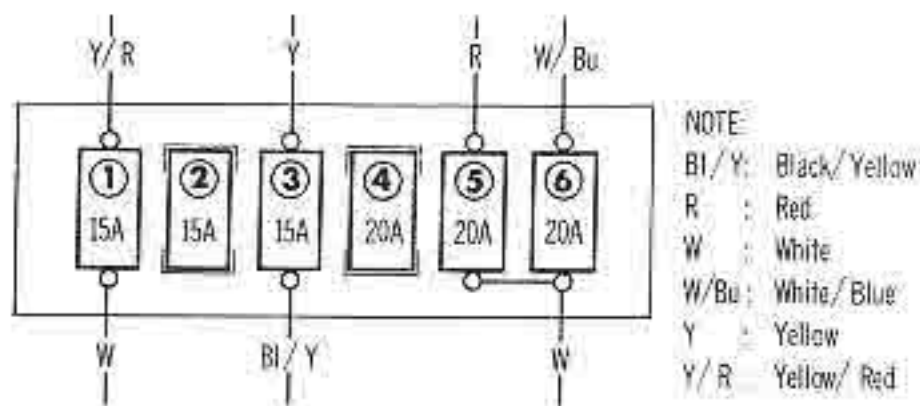



## LIGHTING SYSTEM

### Headlights

#### Replacement

After raising the hood, remove the headlight retaining ring by loosening the two screws (screws ①).

Remove the headlight unit from socket,

Position the "TOP" marking on the lens upward when installing headlight.

**RATING: 12V-50/40 W (SAE 6012)**

#### Aiming

IF THE ILLUMINATION ANGLE IS IMPROPER, HEADLIGHT AIMING SHOULD BE PERFORMED BY A QUALIFIED HONDA TECHNICIAN OR LICENSED ADJUSTER IN STATES HAVING SUCH REQUIREMENTS.

Screw ② is for horizontal adjustment. Screw ③ is for vertical adjustment. The adjustment should be made with the lights in the high beam position.

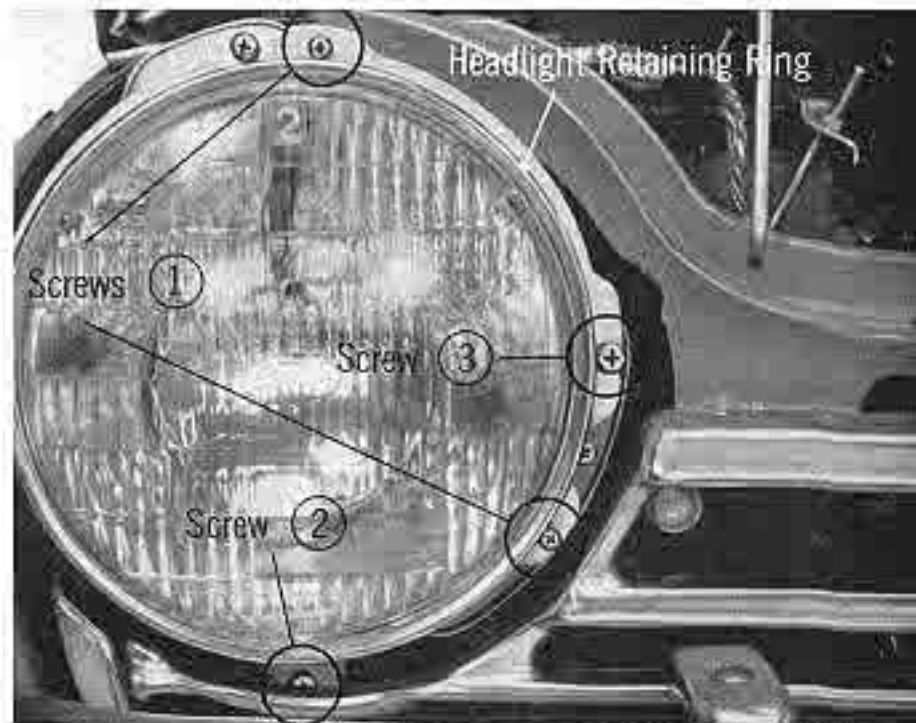

## FRONT TURN SIGNAL LIGHTS AND PARKING LIGHTS

The front turn signal lights and parking lights are incorporated into a single bulb. The lens can be detached by removing the two screws. Remove the bulb by pressing inward and turning slightly to the left.

**RATING: 12 -32/3 cp (SAE 1157)**

The turn signal flashing rate will be affected if an improper bulb is used.

Exercise care to make certain that the gasket under the lens is properly installed to prevent dust and water from entering and causing a drop in the illuminating intensity.

## FRONT SIDE MARKER LIGHTS

Remove the two screws and remove the lens/reflector unit. Remove the bulb socket retaining screw to take out the bulb socket.

**RATING: 12V-4 cp (SAE 67)**

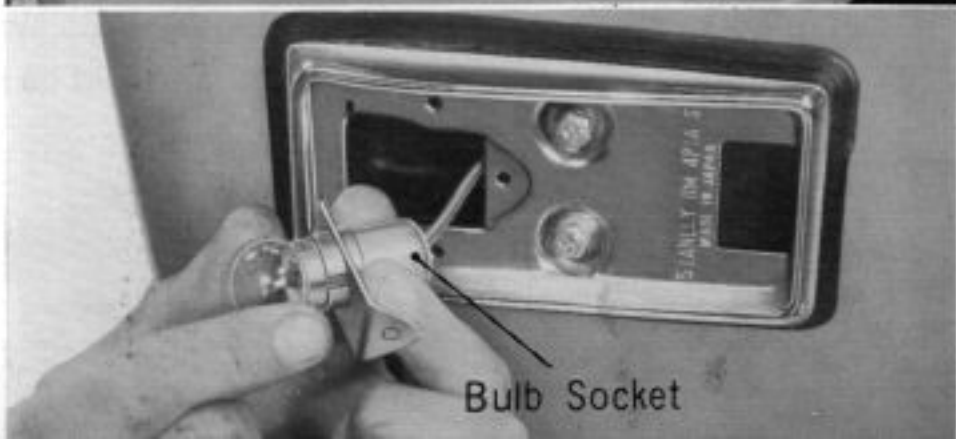
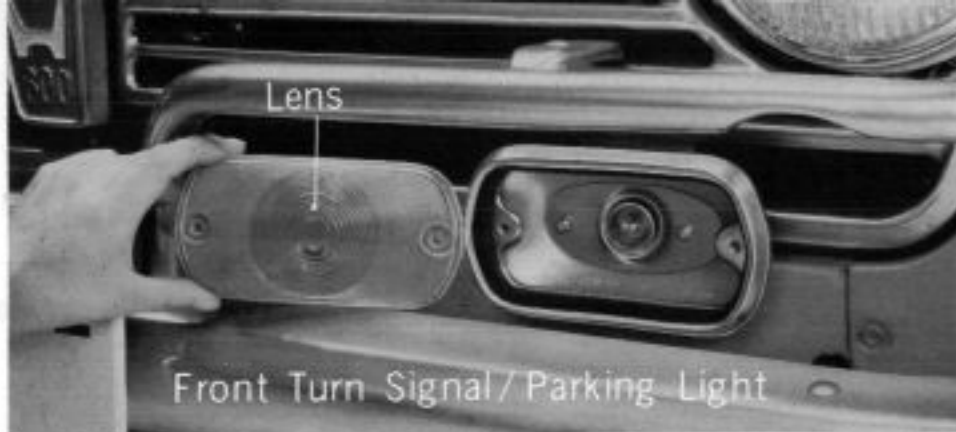

## REAR TURN SIGNAL LIGHTS, STOP LIGHTS AND TAILLIGHTS

After opening the trunk lid, detach the lens from the body by removing the taillight mounting bolts. Pull the socket out then push the bulb in and rotate it counterclockwise.

**RATING: 12 V-32/3 cp (SAE 1157)**

## REAR SIDE MARKER LIGHTS

Remove the two screws to remove the lens. To remove the bulb, Push it in and rotate it counterclockwise.

**RATING: 12 V-4 cp (SAE 67)**

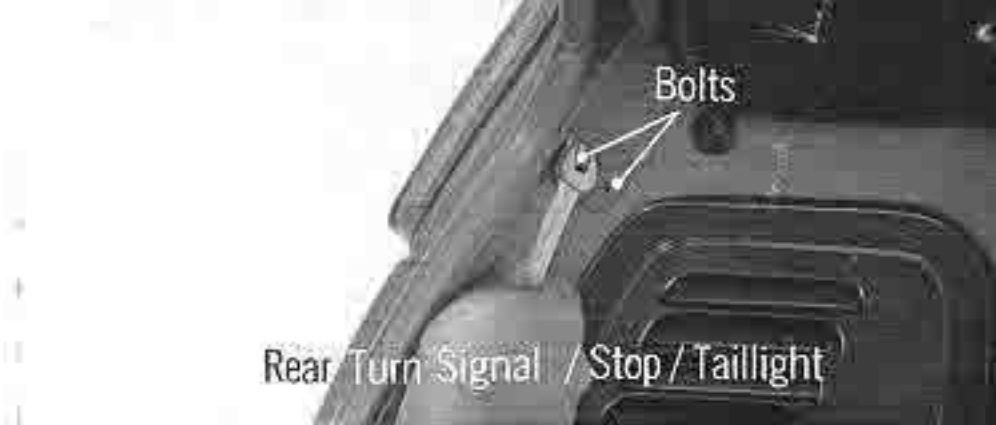

### BACK-UP LIGHTS

Remove the two screws to remove the back-up light lens, then push the bulb in and rotate it counterclockwise.

**RATING: 12 V-32 cp (SAE 1073)**

### LICENSE PLATE LIGHTS

Remove the two screws to detach the lens. Replace the bulb by pushing it in and rotating counterclockwise.

**RATING: 12 V-4 cp (SAE 67)**

### INTERIOR LIGHT

The bulb can be replaced by removing the lens by hand.

**RATING: 12 V-5 W**



Back-up Light



License Plate Light

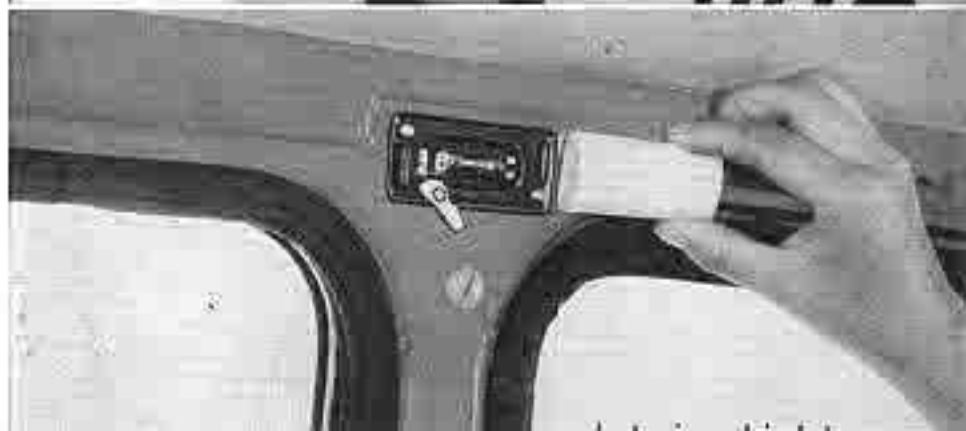

## SERVICE BRAKE SYSTEM

For safe driving, brakes must always be in proper adjustment. Driving with grabbing brakes on one side is dangerous as it may result in loss of control during emergency braking.

## BRAKE PEDAL ADJUSTMENT

The brake pedal travel should be less than 2 1/2 in. (63.5 mm) with normal pedal force applied. The brakes should be checked under driving conditions and any uneven braking, or brake grabbing corrected immediately.

## BRAKE HYDRAULIC FLUID

Raise the hood and remove the reservoir cap to check the level of the hydraulic fluid. If the fluid level is lower than the level line marked on the reservoir, fill the reservoir to the upper level mark. Use only brake fluid which is designated DOT 3 on the container. DOT 3 brake fluid meets the SAE J1703 specification. Outside the U. S. A., use SAE J1703 brake fluid. Be careful not to spill brake fluid on painted surfaces since the paint will be damaged.

When fitting the cap to the reservoir, position the "F" and head of the arrow to the forward direction.

## BRAKE PADS AND LININGS

FOR YOUR SAFETY, THE BRAKE PADS SHOULD BE INSPECTED BY A QUALIFIED HONDA TECHNICIAN AT LEAST ONCE EVERY 3,000 MILES. THE REAR BRAKE LININGS SHOULD BE CHECKED AT LEAST ONCE EVERY 6,000 MILES.

The amount of wear incurred is dependent upon the type of usage—a direct result of your driving habits. It should be noted that the brake pads on the front brake assemblies are more subject to wear than the brake shoe linings on the rear brake assemblies and therefore the pads should be checked more frequently. For safety, the brake pads should be replaced prior to reaching the serviceable limit of 3/32 in. (2 mm), indicated by a red line at the edge of the pads.

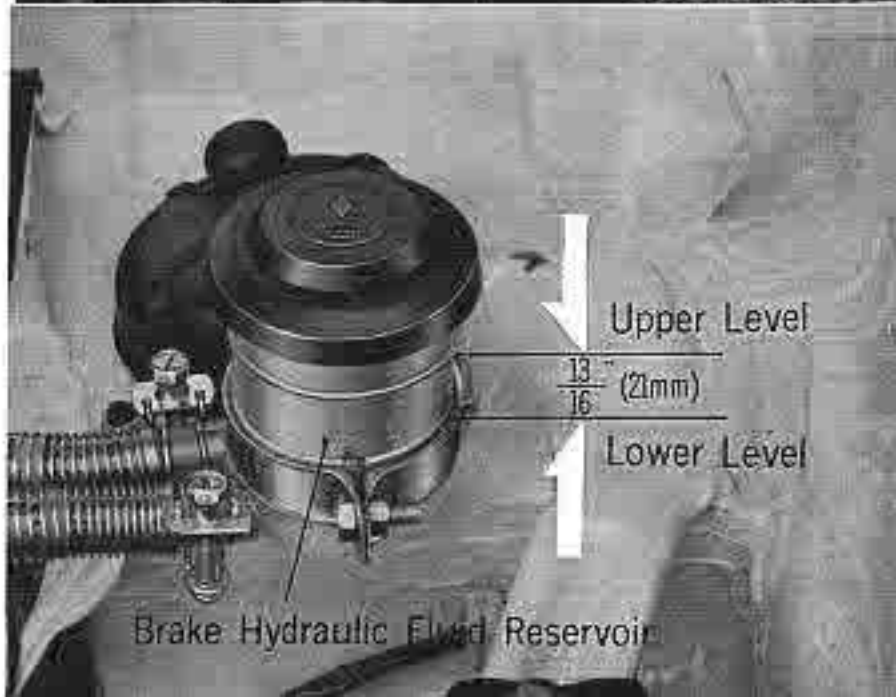

## BRAKE ADJUSTING PROCEDURE

### Front Brake

The front wheel disc brakes do not required adjustment.

### Rear Brake

REAR BRAKE ADJUSTMENT SHOULD BE PERFORMED BY A QUALIFIED HONDA TECHNICIAN.

1. Depress the brake pedal several times.
2. Raise the rear of the car so that the wheel to be adjusted will spin freely.
3. Remove the rubber cap from the adjusting screw.
4. Turn the square hard adjusting bolt clockwise (→) until the wheel can no longer be rotated.
5. Back off the adjusting bolt counterclockwise (←) until the wheel just turns free.

**NOTE:** After adjustment, drive and operate the brake to be sure that both brakes are correctly adjusted without giving any sign of pull to one side.

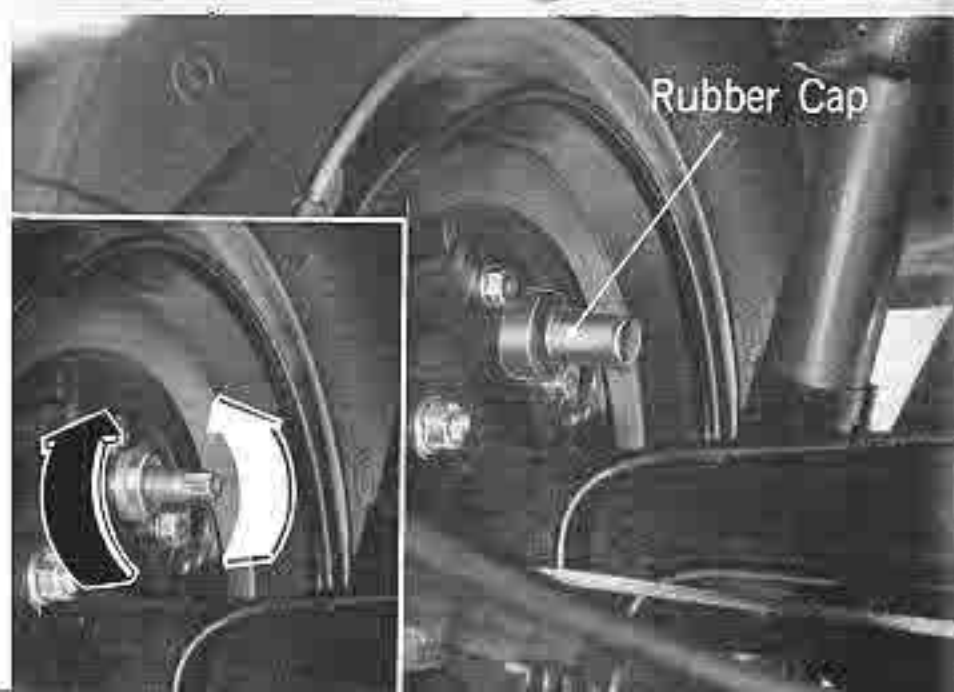
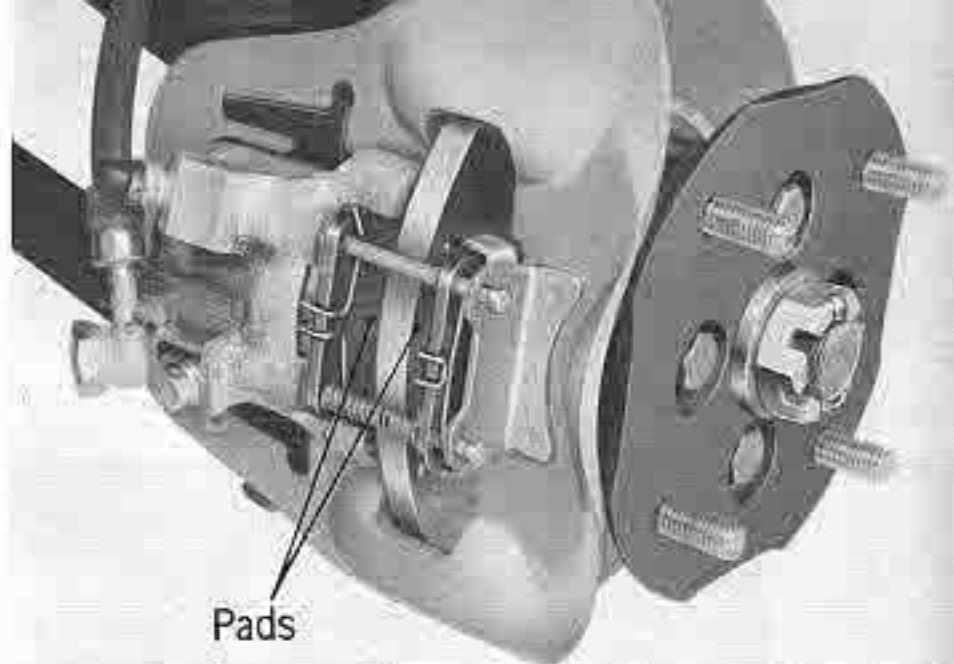

## PARKING BRAKE

PARKING BRAKE ADJUSTMENT SHOULD BE PERFORMED BY A QUALIFIED HONDA TECHNICIAN.

Adjust the parking brake so that the rear wheels are completely locked with the ratchet pawl in the 2<sup>nd</sup>-3<sup>rd</sup> ratchet notch. Make the adjustment by turning the adjusting nut as required.

### Cable End Movement

**F →** : To increase the lever travel

**R ←** : To decrease the lever travel

Make the parking brake adjustment only after the rear brake has been properly adjusted

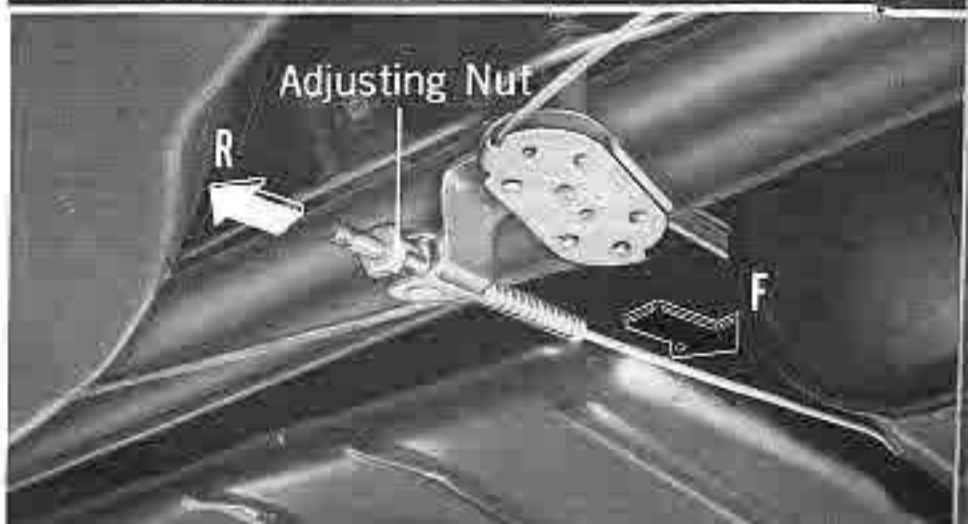
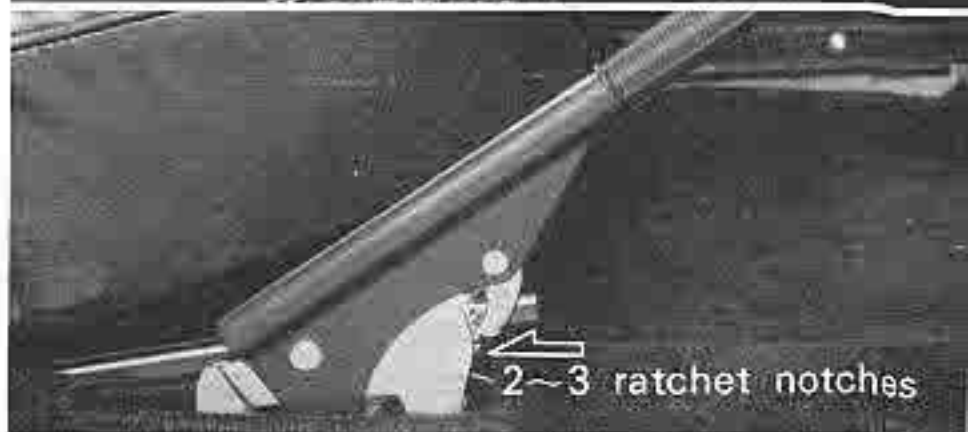

## LUBRICATION SERVICE

### ENGINE AND GEAR OIL

It is extremely important to use proper lubricant for your HONDA 600 SEDAN. This will assure you of long lasting maximum performance. Extended use of dirty oil or oil which has become diluted will seriously damage the engine and shorten its life.

It is recommended that you use only high quality oil which, according to the label on the can, is intended for Service SE. This classification is superior in heat and oxidation stability. In addition, considerable attention has been given to the compounding of chemical additives to obtain higher load carrying and detergency characteristics so that it will be able to cope with conditions encountered under different driving situations. Select an oil from the table on the next page which has the proper viscosity for the atmospheric temperature range anticipated. Oil selection should be based upon quality and proper viscosity.

**NOTE:** Low quality oils are specifically not recommended. The use of proper engine oils and oil change intervals are your best insurance of continued reliability and performance from your HONDA 600 SEDAN.





## RECOMMENDED LUBRICANTS

TEMPERATURE		GRADE	CLASS
<b>ENGINE OIL</b>			
<b>SINGLE GRADE</b>	-4°F~32°F (-20°C~0°C)	SAE 10W	Certified to meet or exceed US car manufacturer's requirements for Service SE
	32°F~59°F (0°C~15°C)	SAE 20W SAE 20	
	59°F~86°F (15°C~30°C)	SAE 30	
	Above 86°F (30°C)	SAE 40	
<b>MULTI-GRADE</b>	Above 5°F (-15°)	SAE 10W/40	
	5°F~86°F (-15°C~30°C)	SAE 10W/30	
	Above 32°F (0°C)	SAE 20W/40 SAE 20W/50	
<b>GREASE</b>			
Multipurpose		NLGI NO. 2	Multipurpose Type

### NOTE:

1. The temperature indicated in the table is the average atmospheric temperature in which the vehicle is being operated.
2. The engine, transmission and differential form an integral unit housed in the crankcase. Therefore, lubricant is required only in the crankcase.
3. In an extremely cold area where the average atmospheric temperature is below -4°F (-20°C), grade **SAE 5W or 5W/20** oil may be used. However, make sure to change to the proper viscosity oil when the atmospheric temperature changes.

## OIL LEVEL CHECK

The oil level should be checked about five minutes after the engine has been stopped to ensure a correct measurement. Check the oil level by wiping the dipstick off, inserting it all the way, and then drawing it out. Make certain that the level of the oil indicated on the dipstick is between the upper and lower limits. The oil level should never be allowed to drop below the lower limit. When the level is low, add oil through the filler opening bringing it to the upper level on the dipstick. However, be careful not to overfill the crankcase.

**CAUTION:** When pulling the oil level dipstick out, do not force it. A slight twisting motion will make removal easy.

## OIL CHANGE

Remove the drain plug and drain the oil thoroughly; tighten the plug securely before pouring oil through the filler opening. Add fresh oil until the level reaches the upper limit marked on the gauge dipstick. (capacity: 3.2 qt., 3  $\ell$  including oil filter). Draining should be performed only when the engine is warm.

**Change oil at 600 miles, 3,000 miles and thereafter at 3,000 mile intervals.**

Before refitting the engine oil filler cap, wipe off the exterior of the filler neck with a rag, otherwise oil seepage may result.

**CAUTION:** Be sure to fully tighten the cap by aligning the arrow mark on the cap with the corresponding mark on the cover.



## OIL FILTER ELEMENT SERVICING

If the oil filter becomes clogged, the safety valve located in the filter functions to open the by-pass, permitting dirty oil to flow directly to the moving parts. This results in increased wear of the parts since the oil is not being filtered.

The oil filter is mounted to the lower crankcase adjacent to the oil drain plug. To replace the filter, remove the oil filter cover by removing the 17mm mounting bolt, and then take out the element. Be careful to replace all rubber gaskets (with the filter) in the same order as removal. After mounting, check for oil leakage while running the engine.

**Replace the oil filter element at 600 miles, 6,000 miles and thereafter at 6,000 mile intervals.**

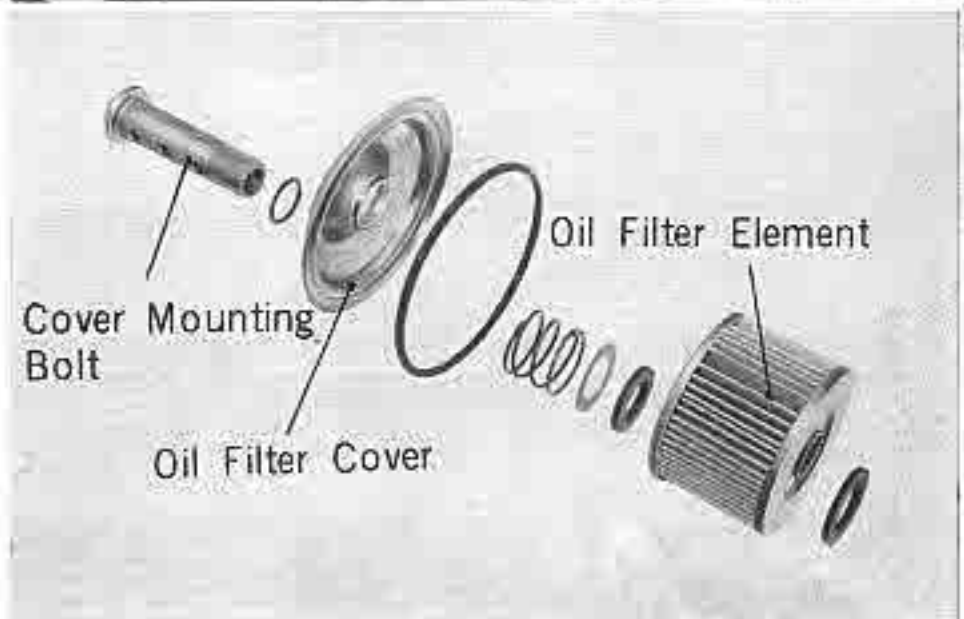
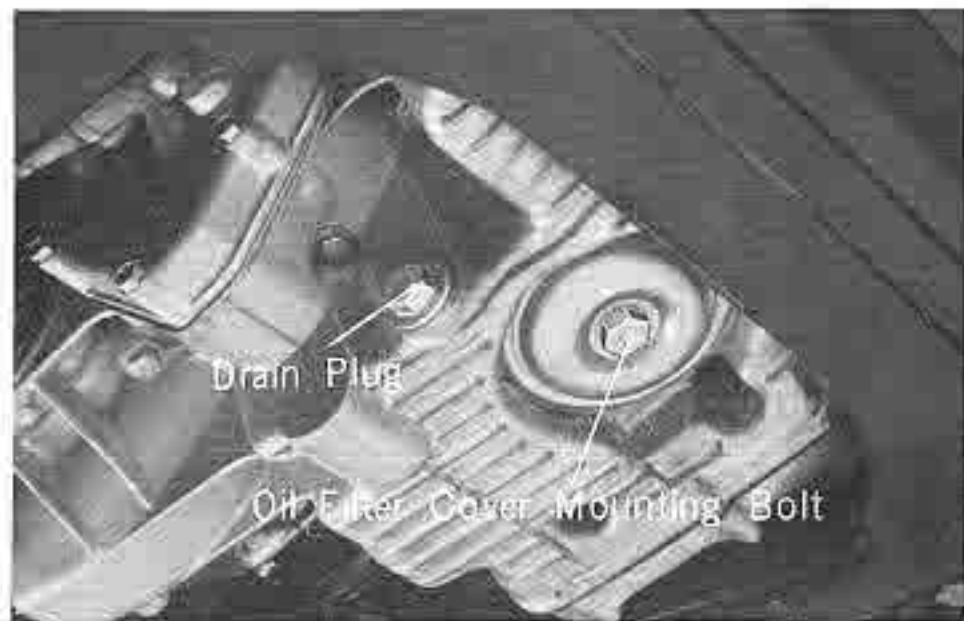

## AIR CLEANER ELEMENT SERVICING

Intake air is filtered through a cellulose (paper element) filter. When this filter becomes clogged, it will cause a drop in the engine power output. To clean the filter, remove the air cleaner case cover and retaining clip, then lift out the cleaner element. Tap the element lightly or blow out the dust with compressed air from the inside. If water or oil are permitted to get on the element. They will block the air flow therefore, handle the element with care

**Clean the element every 6,000 miles. The air cleaner element should be replaced at 12,000 mile intervals.**

An arrow mark and letter "F" are found on the air cleaner cover. When fitting the cover to air cleaner case, position the "F" and head of the arrow to the front

A system to separate oil from the crankcase breather tube is incorporated in a chamber in the air cleaner case.

**Accumulated oil should be drained from the chamber every 3,000 miles by removing the plug.**

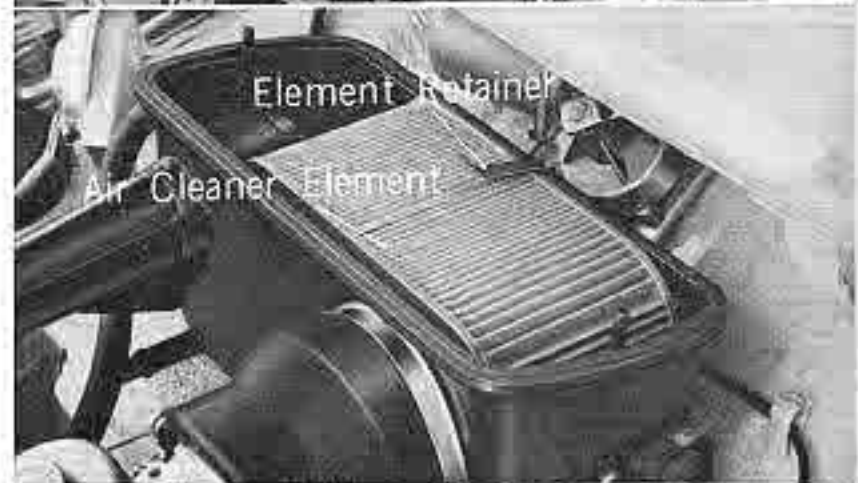

## FAN BELT TENSION ADJUSTMENT

Squeeze the belt together at a point midway between the pulleys and adjust the tension so that the gap between the belt is 15-20 mm (0.59-0.78 in.).

Light belt tension is appropriate as the belt drives only the cooling fan.

To adjust the belt tension, loosen the adjusting nut on the tension pulley and move the pulley until the proper adjustment is achieved. Then, retighten the adjusting nut.

**Check the fan belt tension at 3,000 miles, 6,000 miles and thereafter at 6,000 mile intervals.**

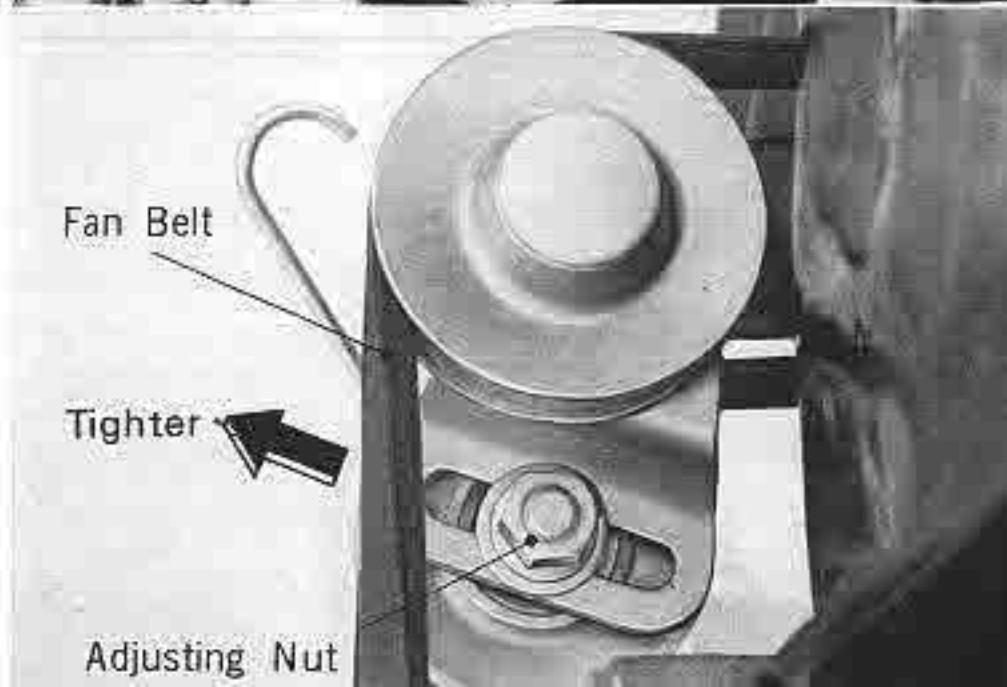
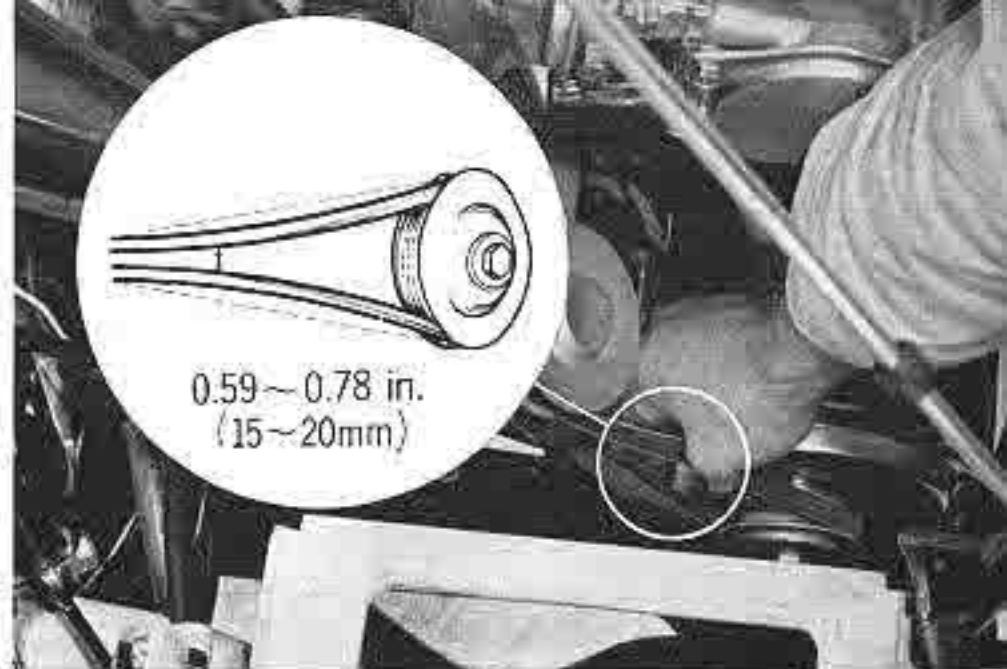

## SPARK PLUG CLEANING

A dirty or carboned electrode will not produce a good strong spark across the plug gap.

Spark plug cleaning requirements vary according to driving conditions and habits and therefore, a standard interval cannot be established.

However, it is recommended that the spark plugs be replaced every 12,000 miles.

The best method of cleaning the plugs is with a plug cleaner; however, a needle and wire brush may also be used to clean the electrode, followed by washing in clean gasoline and drying with compressed air or a rag. Adjust the electrodes to the specified gap 0.7-0.8 mm (0.028-0.032 in.).

Recommended spark plugs: **B-8 ES (NGK)**  
**W-24 ES (Denso)**

Check the spark plug for burning and choose a spark plug of suitable heat range.

**CAUTION:** BEFORE CHANGING SPARK PLUG HEAT RANGE, CONSULT YOUR HONDA AUTOMOBILE DEALER.



Spark Plug Wrench



## VALVE CLEARANCE ADJUSTMENT

VALVE CLEARANCE ADJUSTMENT SHOULD BE PERFORMED BY A QUALIFIED HONDA TECHNICIAN.

Improper valve clearance will result in accelerated wear of the valves, rocker arms and camshaft as well as poor engine performance.

### VALVE CLEARANCE-Intake and Exhaust

**0.08-0.12 mm (0.003-0.005 in.) cold**

Valve clearance must be adjusted only when the engine is cold. Remove the camshaft housing cover. Rotate the crankshaft until the left intake and right exhaust valve rocker arms are raised. The left exhaust and right intake valve rocker arms should now be loose. Loosen the locking bolts on these rocker arms and rotate the rocker arm shaft inward to reduce valve clearance or outward to increase it. Tighten the rocker arm locking bolt to 28.9 lb. ft. (4.0 kgm.) and re-check the valve clearance. Rotate the camshaft so that the right intake and left exhaust valve rocker arms are raised and repeat the valve adjustment sequence. Install the camshaft housing cover and tighten the cover bolts.

**Valve clearance adjustment should be performed at 3,000 miles, 6,000 miles and thereafter at 6,000 mile intervals.**

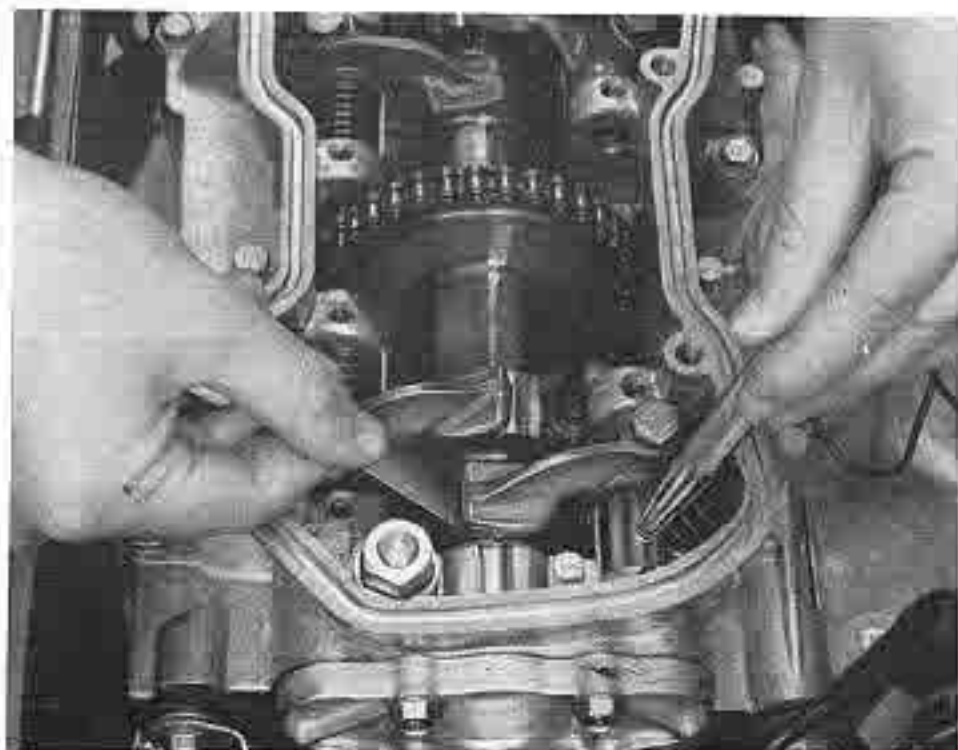

## BREAKER POINT GAP ADJUSTMENT

BREAKER POINT GAP ADJUSTMENT SHOULD BE PERFORMED BY A QUALIFIED HONDA TECHNICIAN.

Remove the breaker compartment cover and turn the 17 mm crankshaft pulley bolt in the direction of engine rotation until the point gap is at its maximum opening. At this position adjust the gap to 0.3-0.4 mm (0.012-0.016 in.).

Loosen the two lock screws shown in the figure and adjust the point gap by the slot in the point arm. Tighten the lock screws upon completion of the adjustment and recheck the gap. Whenever the point gap is adjusted, the ignition timing must also be adjusted.

**Adjustment of the breaker point gap should be performed at 600 miles, 3,000 miles and every 3,000 miles thereafter.**

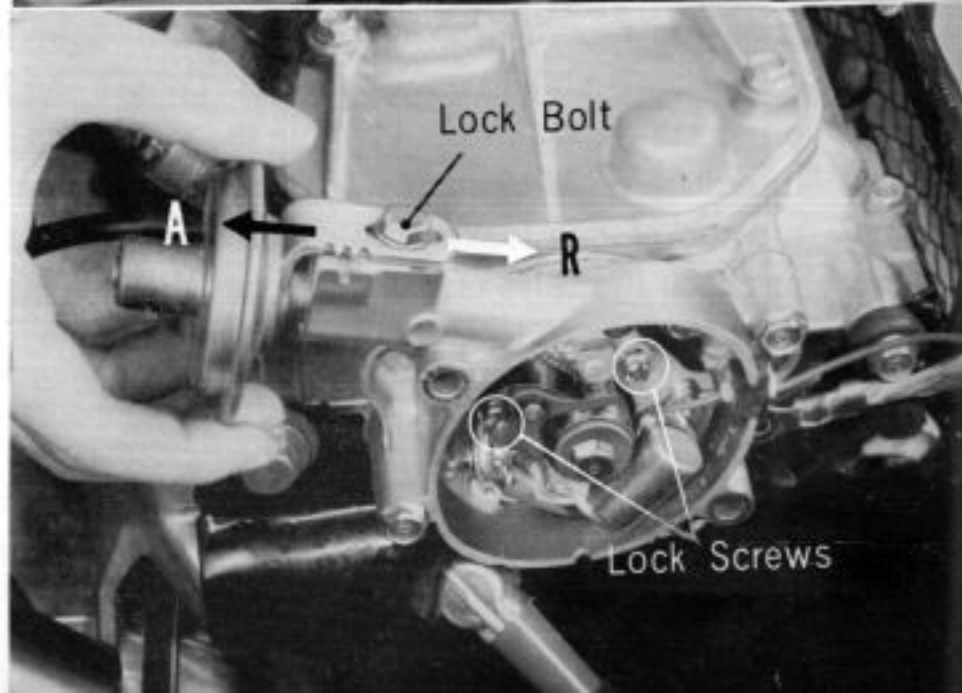



## IGNITION TIMING ADJUSTMENT

IGNITION TIMING ADJUSTMENT SHOULD BE PERFORMED BY A QUALIFIED HONDA TECHNICIAN.

The ignition timing of the HONDA 600 SEDAN is adjusted in the following manner. Turn the ignition switch to the "II" position. Connect a 12V lamp across the primary wiring to ground. Turn the 17mm crankshaft pulley bolt in the direction of engine rotation until the light comes on. When the light just comes on, the notch on the crankshaft pulley should be aligned with the "F" mark on the cover. If the "F" mark and notch are not aligned, turn the crankshaft in the direction of engine rotation until the mark and notch are aligned, then loosen the lock bolt on the vacuum advance mechanism and move the mechanism to the point where the light just comes on. Tighten the lock bolt and re-check the ignition timing.

**A ←:** To advance the ignition timing

**R ⇒:** To retard the ignition timing

Adjustment of the ignition timing should be performed at 600 miles, 3,000 and every 3,000 miles thereafter or whenever the breaker point gap is adjusted.

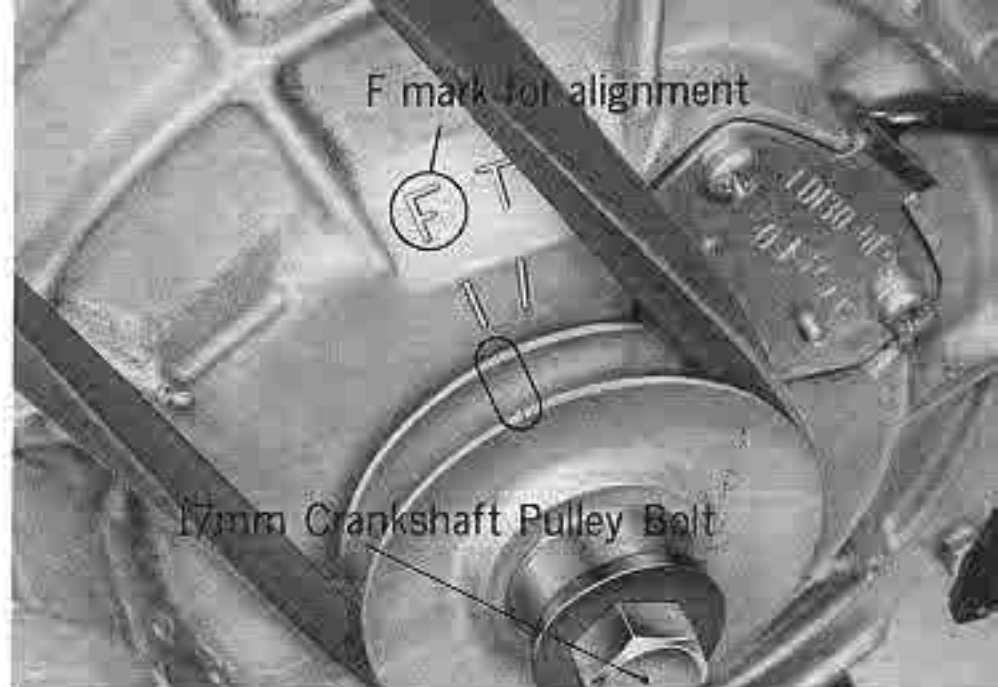

## CARBURETOR ADJUSTMENT

CARBURETOR ADJUSTMENT SHOULD BE PERFORMED BY A QUALIFIED HONDA TECHNICIAN.

The carburetor system adjustment is extremely delicate. Having been properly set prior to delivery, it should not require immediate adjustment. An attempt to correct any engine malfunction only by adjusting the carburetor may result in worsening the condition. If it is diagnosed that the carburetor is malfunctioning, perform the adjustment in the following manner.

### SLOW SPEED (IDLING) ADJUSTMENT

1. NEVER ATTEMPT TO ADJUST THE CARBURETOR UNTIL THE ENGINE HAS REACHED NORMAL OPERATING TEMPERATURE AND THE CHOKE KNOB HAS BEEN COMPLETELY DEPRESSED.
2. Using the throttle stop screw, set the engine idle at 1,100-1,200 R. P. M.
3. Turn the idle mixture screw to achieve the highest possible engine speed.
4. Reset the engine idle at 1,100-1,200 R. P. M. with the throttle stop screw.
5. Repeat steps 3 and 4 until the idle speed cannot be increased by turning the idle mixture screw.

PLEASE CONSULT YOUR HONDA AUTOMOBILE DEALER FOR DETAILED CARBURETOR INFORMATION.



Throttle Stop Screw



Idle Mixture Screw

## EQUIPMENT & MANUALS PROVIDED

Your HONDA 600 SEDAN is equipped with the following spare parts and manuals when delivered.

1. Keys .....2 sets
2. Spare wheel and tire .....1
3. Tools.....1 set
4. Touch up paint .....1
5. Owner's Manual.....1
6. Owner's Warranty and Service Policy Manual .....1

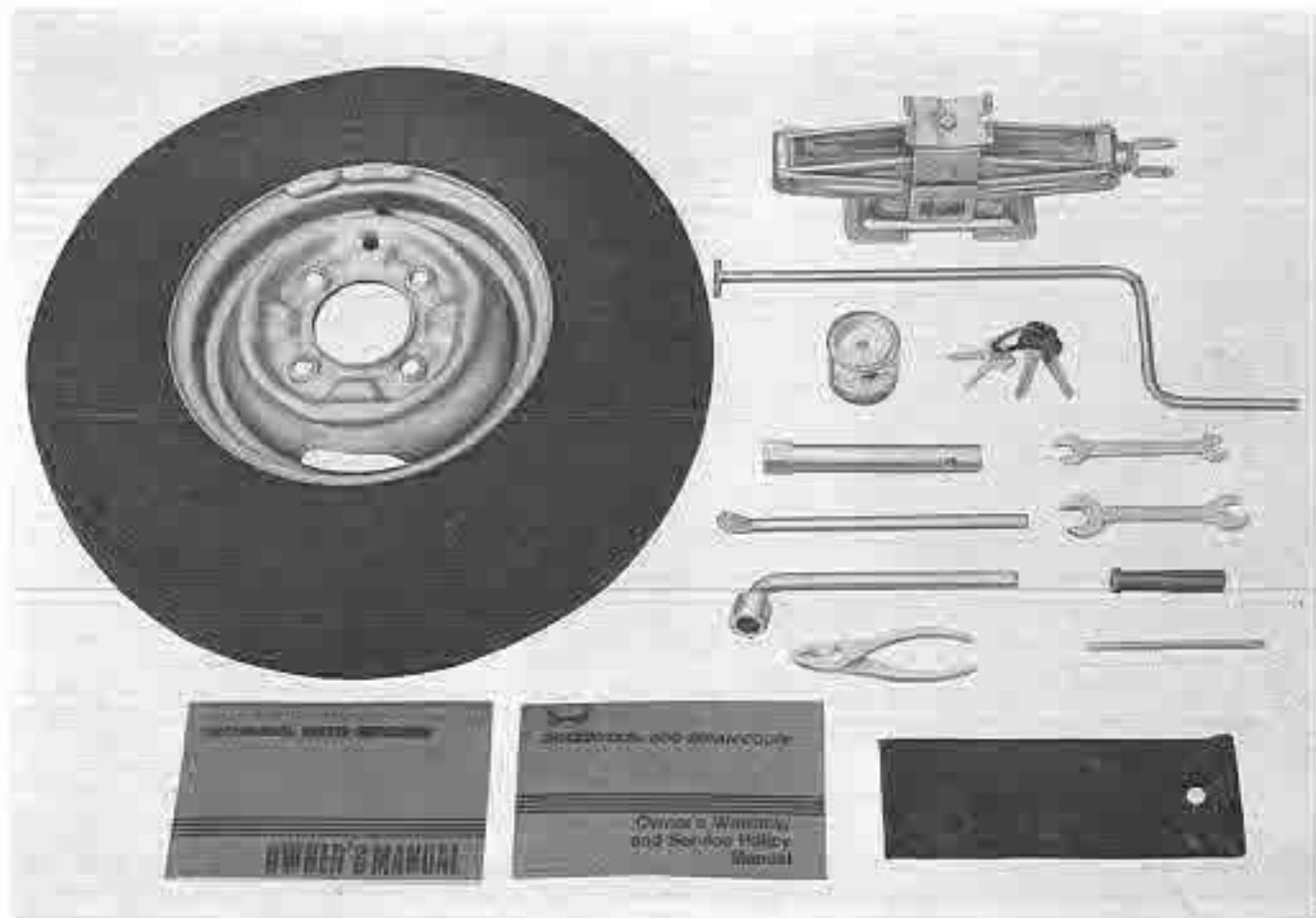

**GENERAL SPECIFICATIONS**

DESCRIPTION		SPECIFICATIONS	
Overall Length		125.59 in. (3,190 mm)	
Width		52.56 in. (1,335 mm)	
Height		52.36 in. (1,330 mm)	
Wheelbase		78.74 in. (2,000 mm)	
Ground Clearance		6.30 in. (160 mm)	
Track	Front	46.06 in. (1,170 mm)	
	Rear	44.60 in. (1,136 mm)	
Turning Circle Diameter		32.9 ft (10 m)	
Curb Weight		1,356.08 lb. (615 kg)	
Maximum Laden Weight		2,066 lb. (937 kg)	
Engine Type		Forced air Cooled 4-stroke Cycle O. H. C. gasoline engine	
Bore X Stroke		2.91 × 2.74 in. (74.0 × 69.6 mm)	
Displacement		36.5 cu-in. (598.4 cc)	
Compression Ratio		8.5 : 1	
Recommended Fuel		Low-lead gasoline with 91 octane number or higher, or regular grade.	
Fuel Tank Capacity		6.9 gal. (26 ℓ)	
Tire Size		Front: 5.20-10	Rear: 5.20-10
Tire Pressure		Front: 30 psi (2.1 kg/cm <sup>2</sup> )	Rear: 24 psi (1.7 kg/cm <sup>2</sup> )

DESCRIPTION	SPECIFICATIONS
Toe-out	0.078 in (2 mm)
Camber	0.5° positive
Caster	1° positive
Battery	12 V-45 AH
Headlights (Sealed-beam)	12 V-50/40 W (SAE 6012)
Front Turn Signal Lights/Parking Lights (combination)	12 V-32/3 cp (SAE 1157)
Gauges, Indicator, Warning Lights	12 V-3 W
Interior Light	12 V-5 W
Side Marker Lights (front and rear)	12 V-4 cp (SAE 67)
Rear Turn Signal Lights, Stop Lights/Taillights (combination)	12 V-32/3 cp (SAE 1157)
Back-up Lights	12 V-32 cp (SAE 1073)
License Plate Lights	12 V-4 cp (SAE 67)
Fuses	15 A×2, 20 A×2
Generator	A. C. Generator (3 phase), 12 V-0.48 KW (at 3,000 rpm)
Starter	12 V-1.0 KW

# I N D E X

	Page		Page
<b>A</b>		<b>C</b>	
ADJUST BRAKES .....	48	CAR CARE RECOMMENDED.....	33
ADJUST BRAKE PEDAL .....	47	CAR HEATER .....	24
ADJUST BREAKER POINT GAP .....	58	CARE OF BATTERY .....	41
ADJUST HEAD RESTRAINT .....	14	CARE OF CHROME .....	35
ADJUST SEAT .....	14	CARBURETOR ADJUSTMENT .....	60
ADJUST SEAT BELT .....	15	CHANGE OIL .....	52
AIR CLEANER ELEMENT SERVICE .....	54	CHECK OIL LEVEL .....	52
AIR DUCTS .....	13	CLEAN SPARK PLUGS.....	56
ARRANGEMENT OF SEAT BELT .....	15	COLD STARTING .....	29
ASHTRAYS .....	25	COMBINATION LAP AND SHOULDER BELT.....	15
<b>B</b>		COMPRESSION BRAKE .....	31
BACK-UP LIGHTS .....	46	CONTENTS .....	2
BATTERY CARE .....	41	<b>D</b>	
BATTERY WARNING.....	41	DEFROSTER .....	24
BRAKE ADJUSTMENT PROCEDURE.....	48	DISCHARGE WARNING LIGHT .....	26
BRAKE HYDRAULIC FLUID .....	47	DOOR LOCKS .....	10
BRAKE PADS AND LININGS.....	47	DRIVING.....	30
BRAKE PEDAL ADJUSTMENT .....	47		
BUZZER, IGNITION KEY REMOVAL WARNING.....	27		

	Page
<b>E</b>	
ENGINE COMPRESSION BRAKE.....	31
ENGINE NUMBER LOCATION .....	5
EQUIPMENT AND MANUALS .....	61
EXHAUST GAS WARNING .....	28
EXTENDING LUGGAGE COMPARTMENT .....	12
<b>F</b>	
FAN BELT TENSION ADJUSTMENT .....	55
FLUID, HYDRAULIC BRAKE .....	47
FRONT PARKING LIGHT.....	44
FRONT SIDE MARKER .....	44
FRONT TURN SIGNAL.....	44
FUEL GAUGE .....	26
FUEL RECOMMENDATION .....	24
FUEL WARNING .....	24
FUSES .....	42
<b>G</b>	
GAP, BREAKER POINT.....	58
GAP, SPARK PLUG .....	56
GAUGE, FUEL .....	24
GEAR SHIFT .....	30

	Page
GENERAL SPECIFICATIONS .....	62
<b>H</b>	
HAZARD WARNING SYSTEM .....	23
HEAD RESTRAINT ADJUSTMENT .....	14
HEADLIGHT DIMMER SWITCH .....	20
HEADLIGHT AIMING .....	43
HEADLIGHT REPLACEMENT.....	43
HEATER, CAR .....	24
HIGH BEAM INDICATOR LIGHT.....	26
HOOD LATCH .....	11
HYDRAULIC FLUID, BRAKE .....	47
<b>I</b>	
IDENTIFICATION NUMBER LOCATION .....	5
IDLE ADJUSTMENT, CARBURETOR .....	60
IGNITION KEY REMOVAL WARNING BUZZER .....	27
IGNITION SWITCH.....	27
IGNITION TIMING ADJUSTMENT .....	59
IMPORTANCE OF KEYS .....	6
INDICATOR LIGHT, HIGH BEAM.....	26
INDICATOR LIGHT, TURN SIGNAL .....	26
INSTRUMENTS AND CONTROLS .....	7
INSTRUMENT PANEL .....	8

	Page
INTERIOR LIGHT SWITCH .....	21
<b>J</b>	
JACK, PROPER USE OF .....	37
<b>K</b>	
KEYS, IMPORTANCE OF .....	6
<b>L</b>	
LAP AND SHOULDER BELT, COMBINATION .....	15
LATCH, HOOD .....	11
LIGHT, BACK-UP .....	46
LIGHT, BRAKE EMERGENCY WARNING .....	23
LIGHT, DISCHARGE WARNING .....	26
LIGHT, LICENSE PLATE .....	46
LIGHTER .....	25
LIGHT SYSTEM .....	43
LIGHT SWITCH .....	20
LOCKS, DOOR .....	10
LUBRICATION .....	50

	Page
<b>M</b>	
MAIN FEATURES .....	3
<b>O</b>	
ODOMETER .....	26
OIL CHANGE .....	52
OIL FILTER ELEMENT SERVICE .....	53
OIL LEVEL CHECK .....	52
<b>P</b>	
PADS AND LININGS, BRAKE .....	47
PARKING BRAKE .....	49
PARKING LIGHT, FRONT .....	44
PEDAL ADJUSTMENT, BRAKE .....	47
PERIODIC MAINTENANCE .....	32
PROPER USE OF JACK .....	37
<b>R</b>	
REAR SIDE MARKER .....	45
REAR SIDE WINDOWS .....	13
REAR TURN SIGNAL .....	45
RECOMMENDED CAR CARE .....	33



	Page
RECOMMENDED LUBRICANTS .....	51

### S

SAFETY ITEMS TO REMEMBER .....	4
SEAT BELT ARRANGEMENT .....	15
SERVICE BRAKE .....	47
SPEEDOMETER .....	26
SNOW TIRES .....	37
SPARE TIRE .....	38
SPARK PLUG CLEANING .....	56
SPARK PLUG GAP .....	56
SPARK PLUG TYPE .....	56
STARTING PROCEDURE.....	28
STEERING COLUMN LOCK .....	27
SWITCH, HEADLIGHT .....	20
SWITCH, IGNITION .....	27
SWITCH, INTERIOR LIGHT.....	21
SWITCH, LIGHTING .....	20
SWITCH, TURN SIGNAL .....	21
SWITCH, WINDSHIELD WIPER AND WASHER.....	22

### T

TIRE CHAINS .....	39
-------------------	----

	Page
TIRE PRESSURES .....	39
TIRE ROTATION .....	38
TOOL KIT .....	36
TOOLS.....	36
TOWING .....	40
TREAD WEAR INDICATOR.....	39
TRUNK LID LOCK .....	12
TURN SIGNAL LIGHT SWITCH .....	21

### V

VENTILATION .....	13
VALVE ADJUSTMENT .....	57

### W

WASH AND POLISH .....	34
WHEELS .....	39
WINDSHIELD WIPER AND WASHER.....	22
WARNING LIGHT, BRAKE EMERGENCY .....	23
WARNING LIGHT, DISCHARGE .....	26
WARNING LIGHT, HAZARD .....	23
WARNING LIGHT, PARKING BRAKE.....	26

The information and specifications included in this publication were in effect at the time of approval for printing. Honda Motor Co., Ltd. reserves the right, however, to discontinue or change specifications or design at any time without notice and without incurring any obligation whatever.

---

**HONDA MOTOR CO., LTD.**  
**TOKYO, JAPAN**

---



**HONDA MOTOR CO., LTD.**